

What is in the Box?

Clear a work area.
Ensure the packaging is the right-way up.
Open the packaging carefully.
Lift out each item, identify it, and carefully place it to one side.

Top cover
Base unit with tone-arm
Turntable platter with belt
Rubber mat
Head-shell with cartridge
Counterweight for the tone-arm
Hinges x 2

Cables x 3, comprising
USB cable (type-A - type-B)
Stereo phono plugs - Stereo phono plugs
Stereo phono sockets - 3.5mm stereo plug

Mains power adaptor with EU and UK pin options

We recommend that all packaging is kept to allow the turntable to be safely transported in the future.

Features

- Counterweight**
This is used to set the tracking force.
- Anti-skating control**
This is used to set the anti-skating force.
- Cueing lever**
Use this lever to lower and raise the tone-arm.
- Tone-arm rest and securing clip**
This holds the tone-arm in place when not in use.
- Head-shell**
This holds the cartridge and stylus.
- 33 / 45 r.p.m. speed switch**
Selects the speed for the record to be played.
- Platter and rubber mat**
Place the record here for playing.
- Phono sockets (right and left)**
Audio output to an amplifier.
Red = Right channel; White = Left channel.
- Pre-Amp On/Off Switch**
Controls use of the built-in phono preamplifier.
If connected to a Line or Aux input set this switch to On.
- USB port**
Connect to a computer for making recordings.
- Auto Stop On/Off switch**
Controls the use of the automatic switch off.
- DC input socket**
- Power On/Off switch**

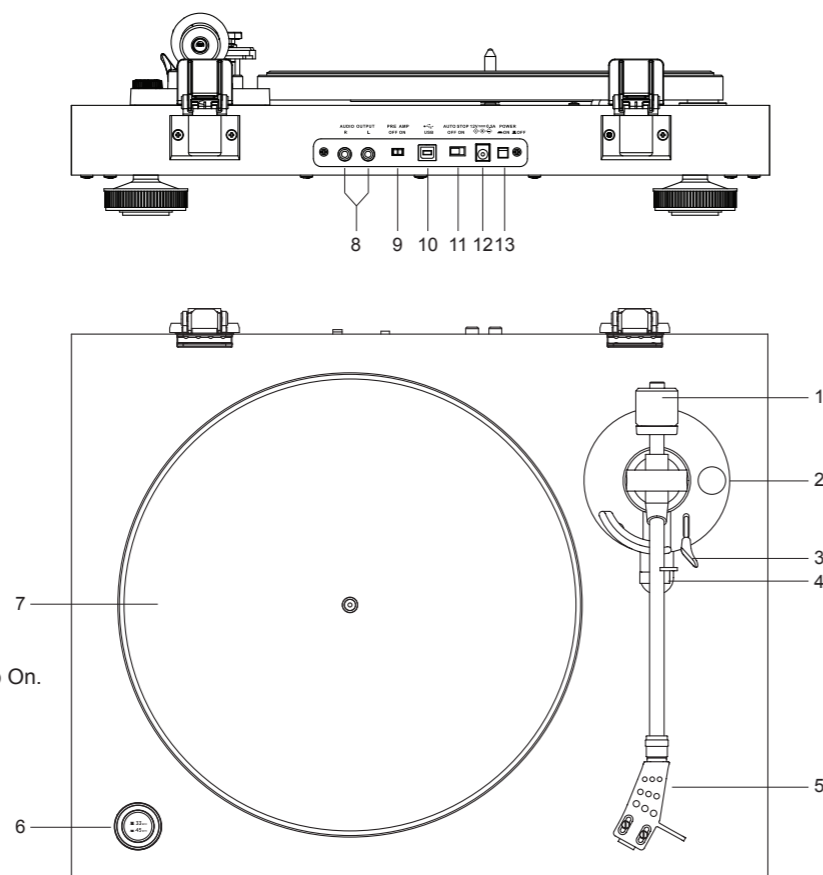

STEP 1 - Assembling your turntable

Assembling the turntable (part 1)

- Unwrap the base unit, taking care not to put pressure on the tone-arm or the cueing lever.
- Do not assemble the platter onto the base just yet.** There is less chance of damage to the cartridge and stylus if the tone-arm is assembled and balanced first.
- Ensure that the tone-arm is locked on its rest with the securing clip.
- Take the head-shell and identify the locating pin on the head-shell connector. **Do not remove the stylus cover at this time.**
- Align the locating pin on the head-shell connector with the slot in the socket at the end of the tone-arm.
- Gently push the head-shell into the tone-arm, at the same time rotate the locking ring at the end of the tone-arm to pull the two parts together. Note that the locking ring rotates anti-clockwise when viewed from the front.
- Tighten the locking ring gently by hand. Do not apply force or use any tools.
- Slide the counterweight on to the tone-arm, rotating it clockwise when viewed from the rear until it engages and some slight resistance is felt.

Note that the scale on the counterweight rotates freely. The counterweight itself must be rotated in order to engage correctly with the tone-arm.

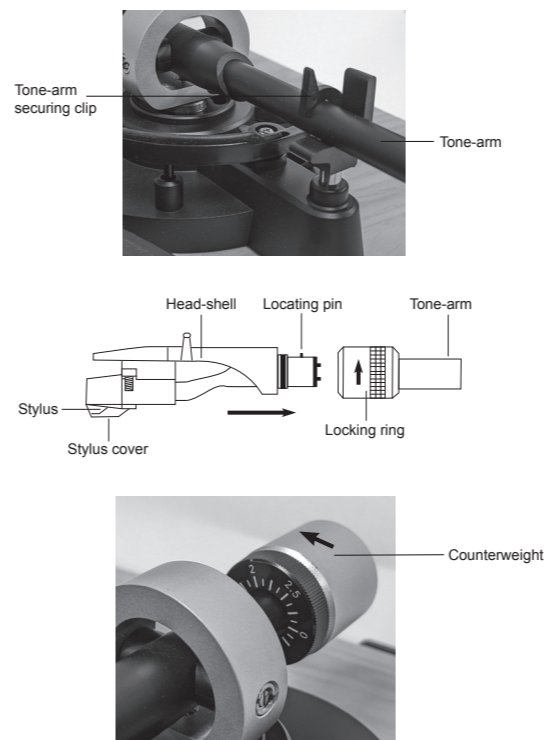

When removing the stylus cover, **do not touch the stylus**. Damage caused to the stylus by mishandling is not covered by the guarantee. When balancing the tone-arm it is important that the **stylus never contacts the turntable platter, mat or base**.

- When you have balanced the tone-arm, place it so that it is again secured on its rest using the securing clip.
- Carefully replace the stylus cover.
- Keeping the counterweight in place, rotate the scale on the front of the counterweight so that it reads zero.
- We recommend that a tracking force of 3.0 grams is used for the supplied cartridge. The tracking force should not exceed 4.0 grams.
The counterweight adjusts the tracking force by 3.0 grams for one complete revolution. Therefore the scale on the counterweight will read zero when the tone-arm is balanced and also when the tracking force is set to 3.0 grams.
- Rotate the counterweight and scale together (clockwise, viewed from the rear) so that the counterweight moves further towards the tone-arm pivot and so that the scale then reads the desired tracking force. Please see the photos to the right showing the counterweight setting when first balanced and then after setting the tracking force. Note that the counterweight is closer to the tone-arm pivot after setting the tracking force.
- Adjust the anti-skating control next to the tone-arm pivot so that it also reads 3.0 grams. Note that this adjustment should normally be set to match the chosen tracking force.

Note: An incorrect tracking weight can have a significant effect on the quality of the audio when playing records. If the tracking weight is set too low or too high then excessive wear to the stylus or damage to the surface of the record may be caused.

Step 3 - Assembling the turntable (part 2)

- Unpack the platter and identify the drive belt.
- Place the platter on the spindle. Use one of the holes in the platter to access the drive belt and place it over the pulley of the drive motor.
- Slowly rotate the platter by hand to ensure that it moves freely and that the belt is not twisted.
- Place the rubber mat on the platter.
- Fit the two hinges onto the top cover. Note that the hinges are sprung and will tend to spring away from the cover.
- Locate the other end of the hinges in the two sockets at the rear of the turntable base.
- Lower the cover into place over the platter and tone-arm.

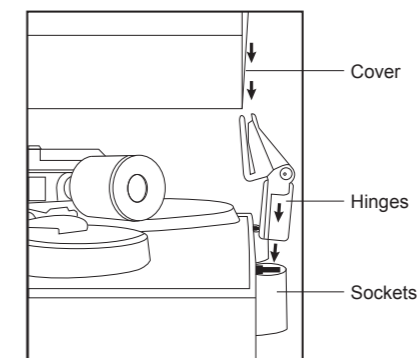

STEP 2 - Setting the tracking force

- Set the anti-skating control to zero.
- Raise the cueing lever.
- Unclip the tone-arm from its securing clip so that it can move freely.
- Take the head-shell and observe that it is currently unbalanced. At this point the head-shell should drift upwards.
- Rotate the counterweight so that it moves further onto the tone-arm.
- Keep checking the balance by lowering the cueing lever to see whether the tone-arm falls, rises or remains level. Take care when lowering the tone-arm that the stylus does not come into contact with the turntable base.
You should ignore the scale on the front of the counterweight at this time.
- Adjust the counterweight further by rotating the counterweight so that it moves in or out until the tone-arm is balanced and remains level when the cueing lever is lowered.
- Carefully remove the stylus cover and adjust the counterweight again until the tone-arm is balanced.

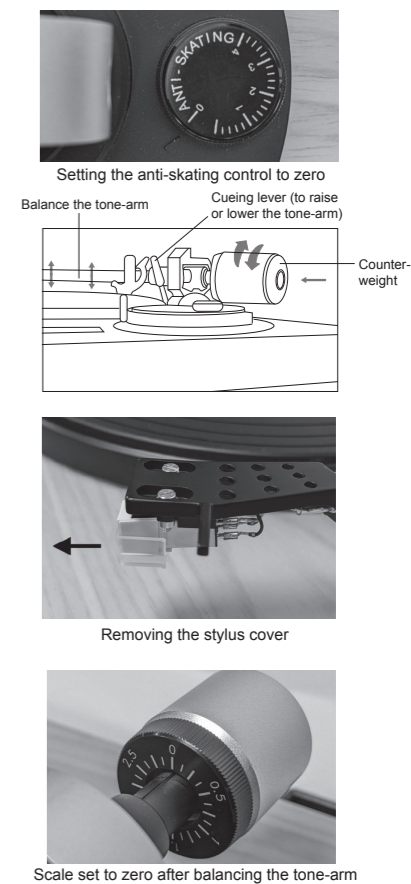

Scale set to zero after balancing the tone-arm

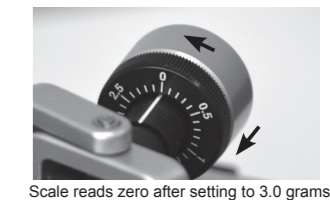

Scale reads zero after setting to 3.0 grams



Anti-skating control set to 3.0 grams



Underside of the platter
Drive belt

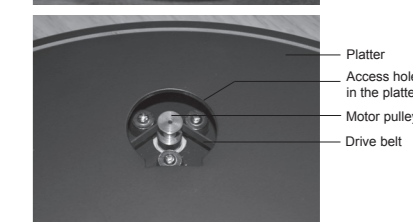

Platter
Access hole in the platter
Motor pulley
Drive belt

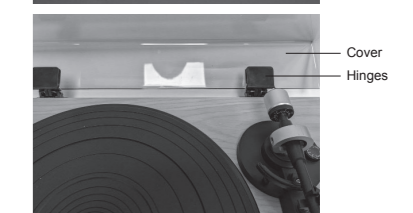

Cover
Hinges

STEP 4 - Connecting the turntable

Mains adaptor

1. Assemble either the UK or EU pins onto the mains power adaptor to suit the mains sockets installed at your location.
2. Note that the rounded end of the pins section needs to engage with the adaptor before the rectangular end.
3. It is important to check that the pins are fully secured to the adaptor before it is used.
4. Plug the DC lead from the mains adaptor into the DC input socket on the back of the turntable.
5. Plug the adaptor into a suitable mains socket.

The AC adaptor should be disconnected from the mains supply and from the turntable when not in use.

IMPORTANT: The mains adaptor is used as the means of connecting the product to the mains supply. The mains socket and any multi-way mains block used for the product must remain accessible during normal use. In order to disconnect the product from the mains, the mains adaptor should be removed from the mains socket completely. Use only the mains adaptor provided with the product, or a genuine replacement provided by Roberts Radio. The use of alternative adaptors will invalidate the guarantee.

6. Switch on at the mains socket and then switch on using the **Power On/Off** switch next to the DC input socket.
7. Release the tone-arm securing clip. Raise the cueing lever fully to raise the tone-arm. Move the tone-arm towards the platter. Observe that the platter rotates, and that its speed changes according to the speed switch setting.
8. Return the tone-arm to its rest and secure it. Observe that the platter stops rotating.

Connecting the turntable

The turntable cannot play music without being connected to a device providing amplification and one or more loudspeakers. This device may be a hi-fi system, a radio or sound system, a soundbar, a multi-room speaker, or just about any audio device with a spare auxiliary input.

Many Roberts products are compatible with the turntable. These include the Revival RD70 radio, the Bluetooth 300 sound system, and the Stream 94i internet radio.

1. If you are connecting the turntable to a hi-fi amplifier or receiver with a built-in phono preamplifier you should set the Pre-amp switch on the back of the turntable to Off. In all other cases you should set the Pre-amp switch on the back of the turntable to On (as shown).
2. Using the supplied audio cables, connect two phono sockets on the back of the turntable to the Auxiliary input, Line input or Phono input on the chosen amplifying device.

To connect to a hi-fi system you would typically use the cable with phono plugs at each end. To connect to devices with an auxiliary input you would typically use the cable with phono plugs at each end in combination with the short adaptor cable to convert the connection to a 3.5mm plug.

3. Switch on the amplifying device and select the input to which you have connected the turntable. Select a moderate volume level.
4. At this point, nothing should be heard. If there is audible hum, check that all of the plugs and sockets are securely connected.

STEP 5 - Playing a record

1. Ensure that the record is clean and dust free. Use a record cleaner if required.
2. Carefully place the record on the platter and set the speed switch to 33 or 45 r.p.m. as needed for the record.
3. Carefully remove the stylus cover by pulling it forwards.
4. Unclip the tone-arm securing clip. Raise the cueing lever fully to raise the tone-arm.
5. Position the tone-arm so that the stylus is centred above the lead-in area of the record.
6. Lower the cueing lever. The tone-arm will drop slowly and the stylus should then settle into the groove at the start of the record which will then start playing.
7. You may wish to gently lower the dust cover while the record is playing. Do not let it close suddenly to avoid a sudden jolt to the tone-arm and stylus.
8. Provided that you have everything connected correctly, you will be able to listen to the record through your connected equipment.
9. At the end of the record, the turntable will switch off.
Note that the automatic switch off feature is dependent on the placement of the run-out groove at the end of the record and may take a few seconds to operate. In the event that the turntable switches off prematurely, you will need to set the Auto Stop switch on the rear panel to Off.
10. Raise the cueing lever and return the tone-arm to its rest. The platter may rotate briefly during this step.
11. Lock the tone-arm in place with the securing clip.
12. If not playing another record for a while, it is recommended to close the dust cover, to switch off the DC power switch at the back of the turntable, and to switch off the mains supply to the turntable.
13. If you wish to stop playing a record before it has finished, use the cueing lever to raise the stylus from the record before returning the tone-arm to its support.

Note: Always use the cueing lever to lower and raise the tone-arm and stylus in order to minimise the risk of damage to either the stylus or the record's surface.

When playing records it is important to ensure that the stylus never contacts the turntable platter, mat or turntable base.

Damage caused to the stylus by mishandling is not covered by the guarantee..

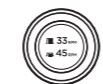
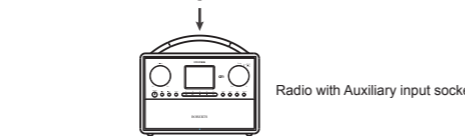
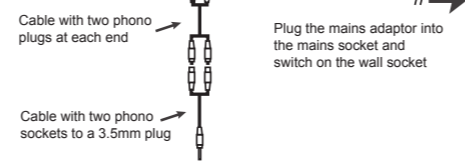
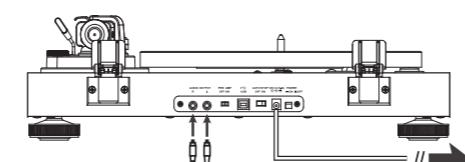
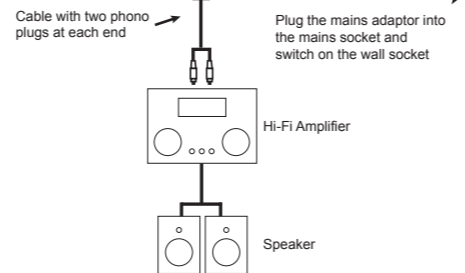
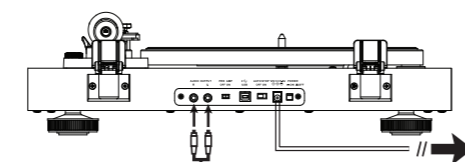
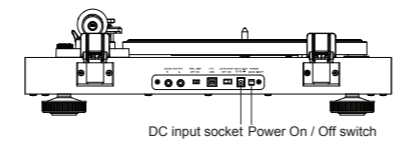
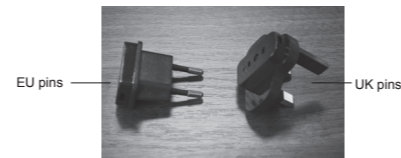

Speed Switch

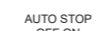

AUTO STOP OFF ON

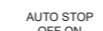

AUTO STOP OFF ON

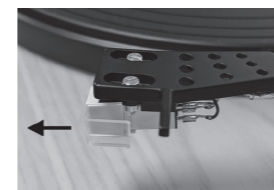

Removing the stylus cover



Stylus positioned over the lead-in groove just before playing

Safety



IMPORTANT: The mains adaptor is used as the means of connecting the product to the mains supply. The mains socket and any multi-way mains block used for the product must remain accessible during normal use. In order to disconnect the product from the mains, the mains adaptor should be removed from the mains socket completely. Use only the mains adaptor provided with the product, or a genuine replacement provided by Roberts Radio. The use of alternative adaptors will invalidate the guarantee.

- Your turntable and AC/DC adaptor should not be exposed to liquids or steam and no objects filled with liquids, such as vases, shall be placed on the turntable or adaptor.
- It is recommended to operate the product such that there is a minimum distance (10cm recommended) to adjacent objects in order to ensure good ventilation.
- The ventilation of the product should not be restricted by covering it with items such as newspapers, tablecloths, curtains etc.
- No naked flame sources such as lighted candles should be placed on the product.
- It is recommended to avoid using or storing the product at extremes of temperature. Avoid leaving the unit in cars, on window sills, in direct sunlight etc.
- There are no user serviceable parts inside this product. The head-shell, stylus and cartridge are considered to be parts that the user may replace if so desired.
- Do not attempt to disassemble any part of the product.
- The product must be used in a moderate climate.

The name plate is located underneath the turntable.

	DC Voltage Power input 12V / 0.5A
	Recycling This product bears the selective sorting symbol for Waste Electrical and Electronic Equipment (WEEE). This means that this product must be handled pursuant to European directive 2012/19/EU in order to be recycled or dismantled to minimize its impact on the environment. The user has the choice to give the product to a competent recycling organization or to the retailer when buying a new electrical or electronic equipment.

Electro-magnetic compatibility advice

In the event of a malfunction due to electrostatic discharge, mains power supply transients or short interruptions, remove the power for 30 seconds and then re-apply power to resume normal operation.

If the product is used in an environment with any ESD Immunity / Radiated Immunity / Conducted Immunity disturbance, the product may malfunction. It will automatically recover to normal when the ESD Immunity / Radiated Immunity / Conducted Immunity disturbance is stopped.

Specifications

Mains Adaptor	AC ~100-240 volts, 50/60Hz (Use only the supplied adaptor)
Operating temperature range	+5°C to +40°C
Cartridge	Moving magnet type Audio Technica AT-3600L Load impedance 47kΩ
Tracking force	3.0 - 4.0 grams
Replacement stylus	Audio Technica ATN-3600L

The company reserves the right to amend the specification without notice

To clean the turntable use a soft lint-free cloth, ideally made from natural fibres in order to prevent a build-up of static electricity which can attract dust. Do NOT use polish or any solvent based cleaners. To remove dust from the mat on the platter, use a slightly damp lint-free cloth, removing the mat first if needed. To clean records, only use a purpose designed record cleaning brush with the record on the platter.

For support with using the recording function and for general troubleshooting, please visit our website at www.robertsradio.com

Guarantee

This product is guaranteed for twenty four months from the date of purchase by the original owner against failure due to faulty workmanship or component breakdown, subject to the procedure stated below. Should any component or part fail during this guarantee period it will be repaired or replaced free of charge.

The guarantee does not cover: 1. Damage resulting from incorrect use. 2. Consequential damage. 3. Product with removed or defaced serial numbers.

N.B. The stylus will not be replaced under this guarantee if it is damaged or broken.

Procedure: Any claim under this guarantee should be made through the dealer from whom the product was purchased. It is likely that your Roberts dealer will be able to attend to any defect quickly and efficiently, but should it be necessary the dealer will return the product to the company's service department for attention. In the event that it is not possible to return the product to the Roberts dealer from whom it was purchased, please contact Roberts Radio using the contact details on the www.robertsradio.com website.

For product repairs falling outside the guarantee period, please refer to the "customer care" tab on the www.robertsradio.com website.

These statements do not affect the statutory rights of a consumer.

Designed & Engineered in the UK
Made in China

ROBERTS RADIO LIMITED

Roberts Radio Ltd, Stoney Lane, Whiston, Prescot, L35 2XW, UK
Glen Dimplex Europe Ltd, Airport Road, Cloghran, Co. Dublin, K67 VE08, Ireland

Roberts

Stylus

Turntable with USB connection and built-in preamplifier



Please read this manual before use



Issue 1



www.robertsradio.com
© 2022 Roberts Radio Limited

