

# ROBERTS

Enjoy Listening

## *Classic 996*

3 Band Portable Radio



Please read this manual before use

## Controls

(Top)

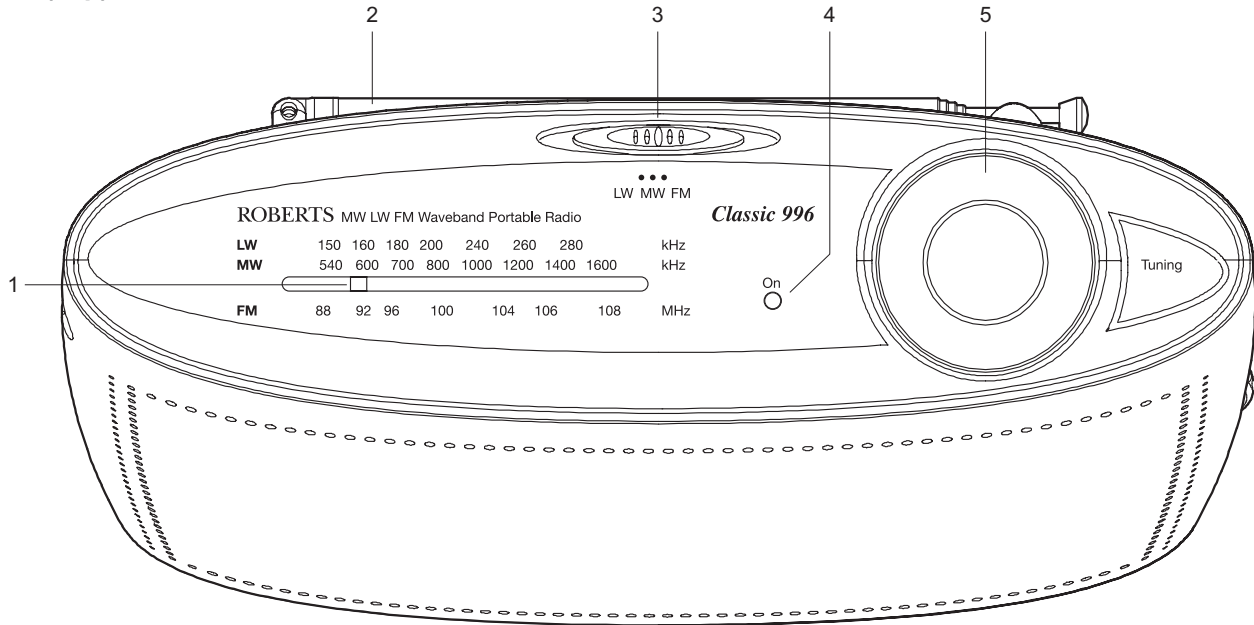

1. Dial scale pointer
2. Telescopic aerial
3. Waveband switch
4. Power on indicator
5. Tuning control

## Controls

(Left)

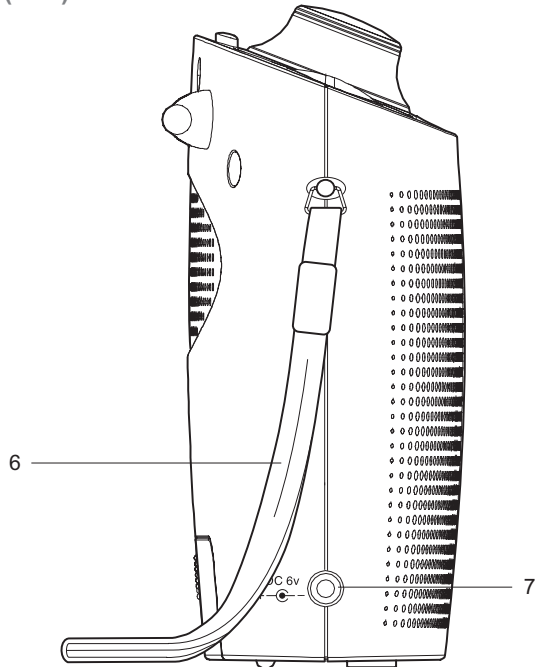

6. Carry strap

7. DC input socket

(Right)

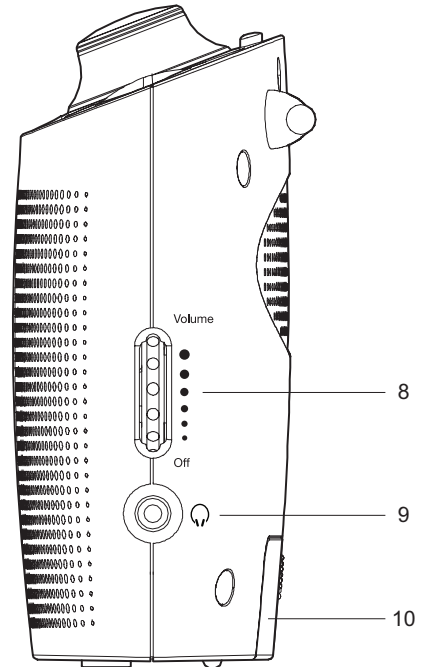

8. Volume / On/Off control

9. Headphone socket

10. Battery compartment

## Battery operation

1. Remove the **battery cover** on the back of the unit by sliding the cover in the direction of the arrow.
2. Insert four LR6 (AA size) batteries into the spaces in the compartment. Take care to ensure all batteries are inserted with the correct polarity as shown next to the battery compartment. Replace the battery cover.
3. Reduced power, distortion and a 'stuttering' sound are all signs that the batteries may need replacing.
4. If the radio is not to be used for any extended period of time it is recommended that the batteries are removed from the radio.

**IMPORTANT:** The batteries should not be exposed to excessive heat such as sunshine, fire or the like. After use, disposable batteries should if possible be taken to a suitable recycling centre. On no account should batteries be disposed of by incineration.

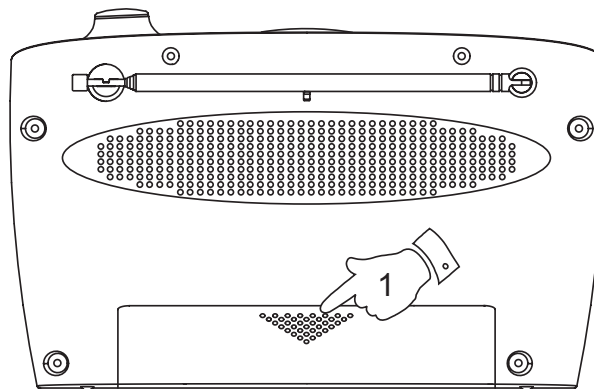

## Operation via an AC adaptor (not included)

The AC adaptor for use with the Classic 996 should provide 6 volts DC output at 300mA centre pin negative.

1. Place your radio on a flat surface.
2. Plug the mains adaptor into the **DC input socket** located on the left hand side of your radio ensuring that the plug is pushed fully into the socket.
3. Plug the other end of the mains adaptor into a standard 13A mains socket outlet and switch on the wall socket. Whenever the adaptor is used the batteries are automatically disconnected.

*The AC adaptor should be disconnected from the mains supply and from the radio when not in use.*

**IMPORTANT:** The mains adaptor is used as the means of connecting the radio to the mains supply. The mains socket used for the radio must remain accessible during normal use. In order to disconnect the radio from the mains completely, the mains adaptor should be removed from the mains socket outlet completely.

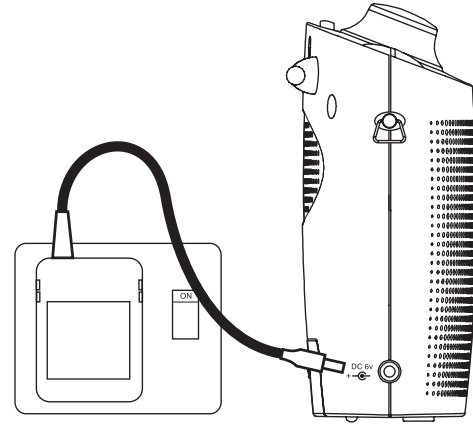

## Operating your radio - FM

1. Switch on your radio by rotating the **Volume control** anti-clockwise until a click is heard. The **Power on indicator** will light up.
2. For FM reception fully extend the **Telescopic aerial** and then angle and rotate for best reception.
3. Set the **Waveband switch** to the FM waveband position
4. Adjust the **Volume control** until a hissing sound is heard.
5. Rotate the **Tuning control** to select the desired station. On FM the tuning scale is marked in Megahertz (MHz).
6. Adjust the **Volume control** to the required setting.
7. To switch off your radio rotate the **Volume control** fully clockwise until a click is heard.

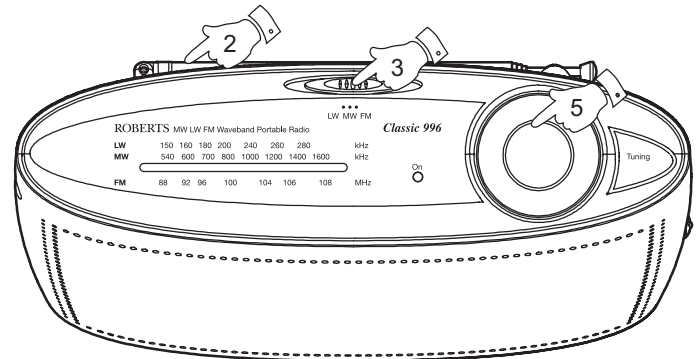
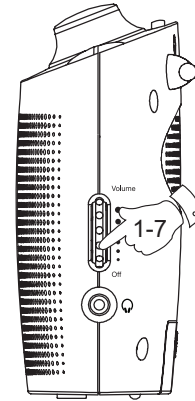

## Operating your radio - Medium and Long wave

1. Switch on your radio by rotating the **Volume control** anti-clockwise until a click is heard. The **Power on indicator** will light up.
2. Select the **Waveband switch** to select either the MW or LW waveband.
3. Adjust the **Volume control** until a hissing sound is heard.
4. Rotate the **Tuning control** to select the desired station. On MW and LW the tuning scale is marked in kilohertz (kHz).
5. For MW and LW reception rotate your radio to the position giving best reception.
6. Adjust the **Volume control** to the required setting.
7. To switch off your radio rotate the **Volume control** fully clockwise until a click is heard.

Note: The telescopic aerial is inoperative on MW and LW.

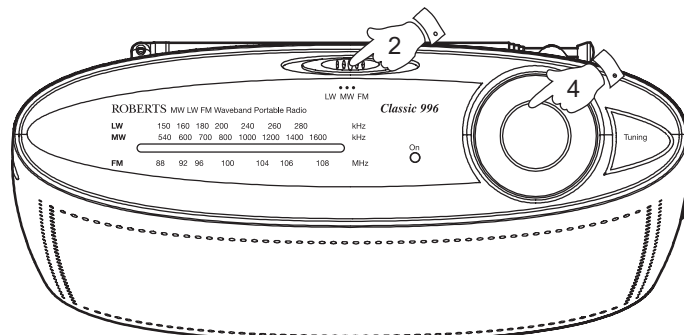
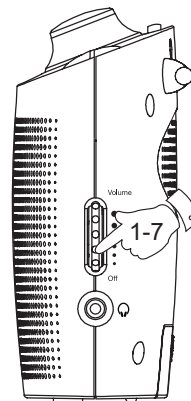

## Headphone socket

A 3.5mm **Headphone Socket** located on the right hand side of your radio is provided for use with either headphones or an earpiece. Inserting a plug automatically mutes the internal loudspeaker.

**IMPORTANT:** Excessive sound pressure from earphones and headphones can cause hearing loss.

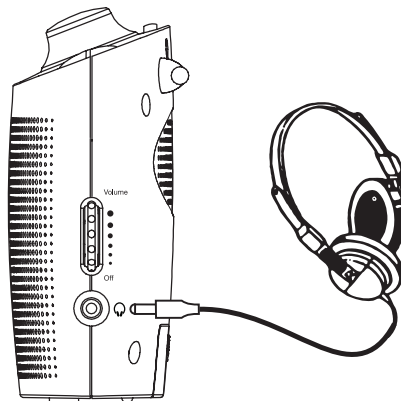



## General

Do not allow this radio to be exposed to water, steam or sand. Do not leave your radio where excessive heat could cause damage such as in a parked car where the heat from the sun can build up even though the outside temperature may not seem too high. It is recommended that the FM band be used wherever possible as better results in terms of quality and freedom from interference will usually be obtained than on the MW or LW bands.

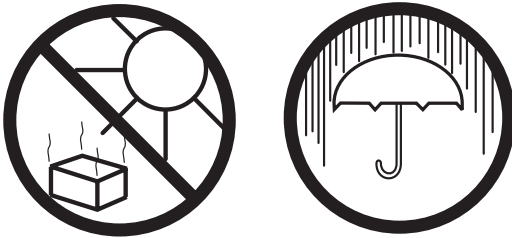

The name plate is located on the back of your radio.

- Your radio should not be exposed to dripping or splashing and that no objects filled with liquids, such as vases, shall be placed on the radio.
- It is recommended to operate the product such that there is a minimum distance (10cm recommended) to adjacent objects in order to ensure good ventilation.
- The ventilation of the product should not be restricted by covering it or its ventilation openings with items such as newspapers, tablecloths, curtains etc.
- No naked flame sources such as lighted candles should be placed on the product.
- It is recommended to avoid using or storing the product at extremes of temperature. Avoid leaving the unit in cars, on window sills, in direct sunlight etc.

## Specifications

### Power Requirements

Mains	AC 230 volts, 50Hz $\sim$ only (adaptor not included)
Batteries	4 x LR6 (AA size)

### Battery Life

Up to 80 hours of listening for 4 hours a day at normal volume using alkaline cells.

### Frequency Coverage

FM	87.5 - 108MHz
MW	522 - 1620kHz
LW	144 - 281kHz

## Circuit Features

Loudspeaker	76mm
Headphone socket	3.5mm dia
Output Power	400mW into 8 ohms
Aerial System	FM      Telescopic aerial
	MW      Built-in Ferrite aerial
	LW      Built-in Ferrite aerial

*The Company reserves the right to amend the specification without notice*

## Guarantee

This instrument is guaranteed for twelve months from the date of delivery to the original owner against failure due to faulty workmanship or component breakdown, subject to the procedure stated below. Should any component or part fail during this guarantee period it will be repaired or replaced free of charge.

The guarantee does not cover:

1. Damage resulting from incorrect use.
2. Consequential damage.
3. Receivers with removed or defaced serial numbers.

N.B. Damaged or broken telescopic aerials will not be replaced under guarantee.

Procedure:

Any claim under this guarantee should be made through the dealer from whom the instrument was purchased. It is likely that your Roberts' dealer will be able to attend to any defect quickly and efficiently but should it be necessary the dealer will return the instrument to the Company's service department for attention. In the event that it is not possible to return the instrument to the Roberts' dealer from whom it was purchased, please contact Roberts Radio Technical Services at the address shown overleaf.

*These statements do not affect the statutory rights of a consumer.*

## ROBERTS RADIO TECHNICAL SERVICES

97-99 Worton Road  
Isleworth  
Middlesex  
TW7 6EG

Technical Helpline :- 020 8758 0338 (Mon-Fri during office hours)

Web site: <http://www.robertsradio.co.uk>



Issue 1

© 2010 Roberts Radio Limited

