

# ROBERTS

## *Swallow 2*

PLL synthesised radio MP3/WMA/CD/USB player



Please read this manual before use

## Contents

<i>Contents</i> .....	1	<i>Erasing a programme</i> .....	17
<i>Controls</i> .....	2-4	<i>MP3/WMA mode</i> .....	18
<i>Battery operation</i> .....	5	<i>Playing an MP3/WMA CD</i> .....	19
<i>Mains operation</i> .....	5	<i>Selecting albums and files</i> .....	19
<i>Operating your radio - FM search tuning</i> .....	6	<i>Repeating a file</i> .....	20
<i>Operating your radio - MW search tuning</i> .....	7	<i>Repeating all files in an album</i> .....	20
<i>Operating your radio - manual tuning</i> .....	8	<i>Repeating all files</i> .....	20
<i>Presetting radio stations automatically</i> .....	9	<i>Playing back files in random order</i> .....	21
<i>Presetting radio stations manually</i> .....	10	<i>Programming tracks</i> .....	21
<i>Recalling a preset station</i> .....	11	<i>Playing a programmed track</i> .....	22
<i>Last station memory</i> .....	11	<i>Editing a programme</i> .....	22
<i>Compact discs</i> .....	12	<i>Adding a new file</i> .....	23
<i>CD-R / CD-RW discs</i> .....	12	<i>USB mode</i> .....	24
<i>Inserting a CD</i> .....	13	<i>Selecting USB mode</i> .....	25
<i>Playing a CD</i> .....	13	<i>General</i> .....	26
<i>Selecting a track</i> .....	14	<i>Mains supply</i> .....	27
<i>Search function</i> .....	14	<i>Headphones</i> .....	28
<i>CD repeat mode</i> .....	15	<i>Specification</i> .....	29
<i>CD random mode</i> .....	15	<i>Circuit features</i> .....	29
<i>Programmed play</i> .....	16	<i>Troubleshooting</i> .....	29
<i>Editing a programme</i> .....	16	<i>Guarantee</i> .....	30
<i>Checking a programme</i> .....	17		

## Controls

(Front)

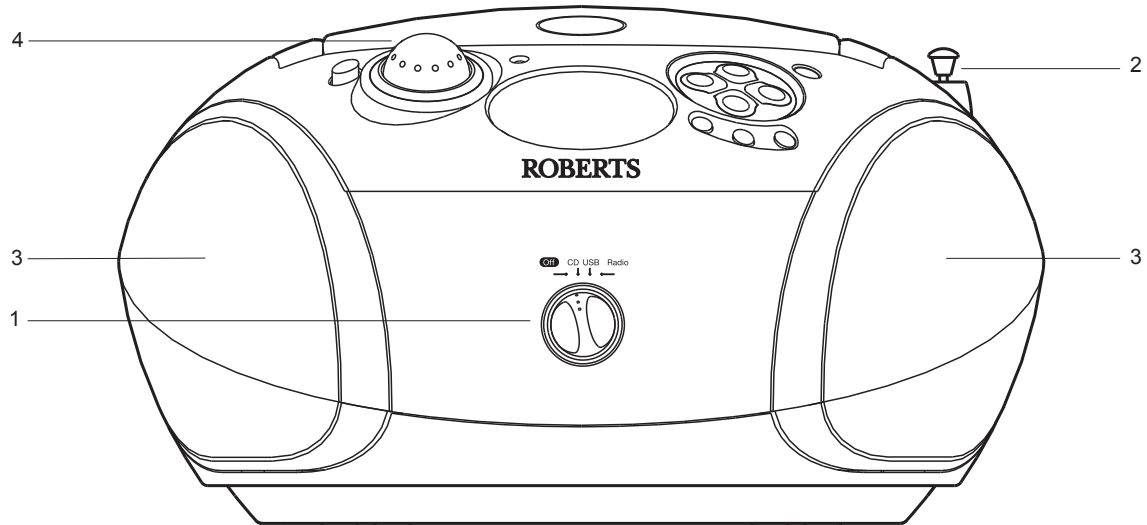

1. Function switch
2. Telescopic aerial
3. Loud speakers
4. Volume control

## Controls

(Top)

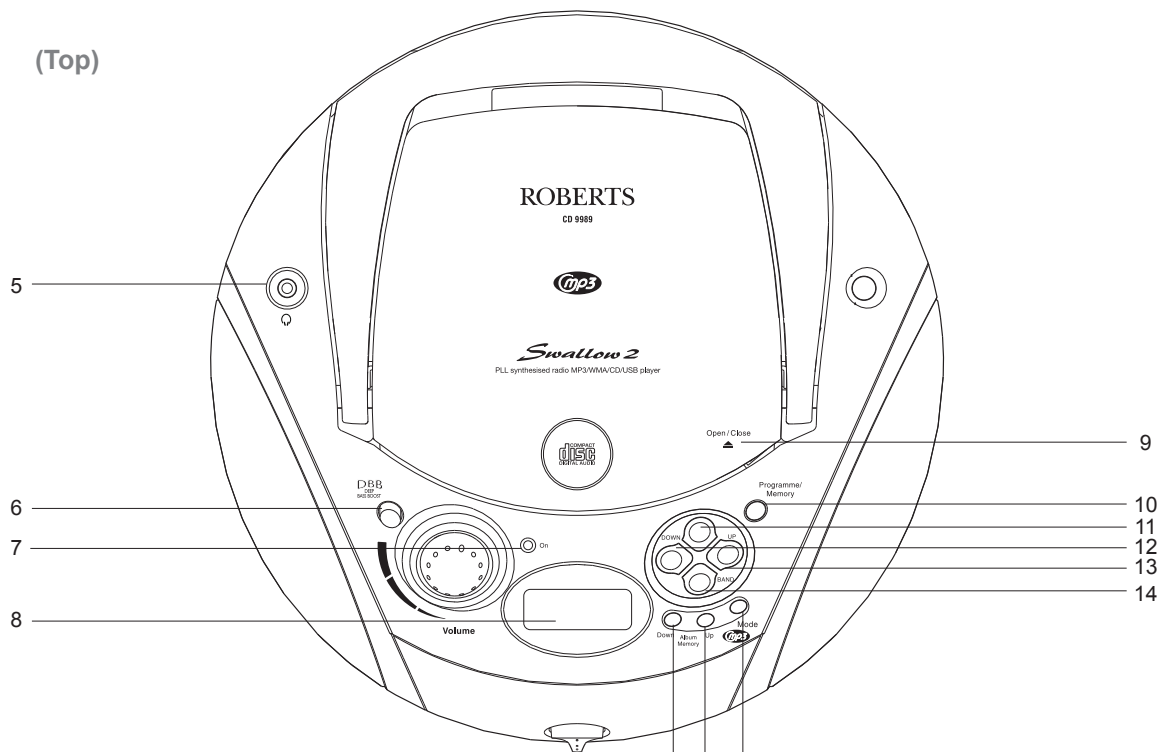

- 5. Headphone socket
- 6. Deep Bass Boost button
- 7. On indicator light
- 8. LCD display

- 9. CD open close
- 10. Programme / Memory button
- 11. Play / Pause button
- 12. Tuning Down / B Skip button

- 17
- 16
- 15

- 13. Tuning Up / F Skip button
- 14. Waveband / Stop button
- 15. Mode button
- 16. Album / Memory up button
- 17. Album / Memory down button

## Controls

(Left side)

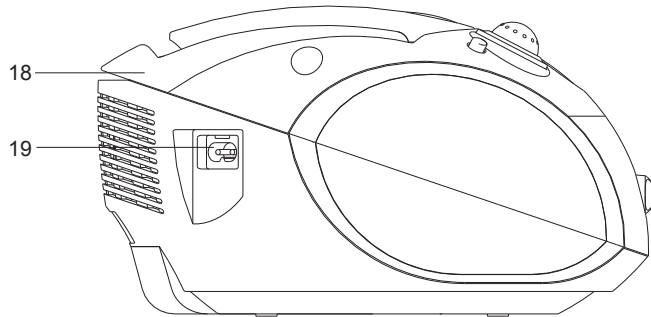

(Right side)

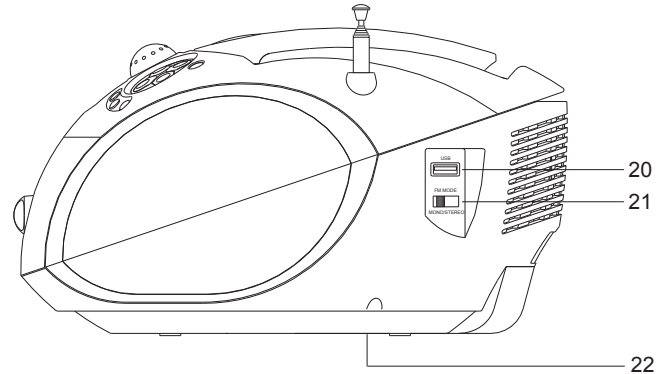

- 18. Handle
- 19. Mains power socket
- 20. USB socket
- 21. FM Mode switch
- 22. Battery compartment

## Aerial storage

When the aerial is in the vertical position it can be collapsed and then pushed partly into the aerial stud for storage (see the right hand illustration above).

For best reception the aerial should be restored to the vertical orientation and fully extended.

## Battery operation

1. Slide the battery cover catch in the direction of the arrow. Open the battery cover.
  2. Fit six LR14 (C size) batteries into the spaces in the compartment. Take care to ensure all batteries are inserted with the correct polarity as shown next to the battery compartment. Replace the battery cover.
  3. Reduced power, distortion and a 'stuttering' sound are all signs that the batteries may need replacing. If your MP3 CD radio is not to be used for a prolonged period of time, remove the batteries to avoid damage by battery leakage.
- We recommend for economy that your MP3 CD radio is used on the mains whenever possible with battery operation for occasional or stand-by use only.

**IMPORTANT:** The batteries should not be exposed to excessive heat such as sunshine, fire or the like. After use, disposable batteries should if possible be taken to a suitable recycling centre. On no account should batteries be disposed of by incineration.

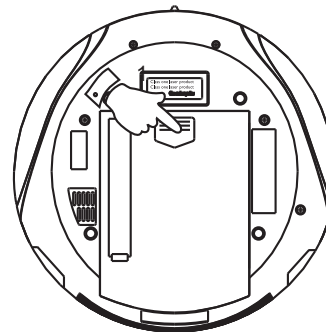

---

## Mains operation

1. Place your MP3 CD radio on a flat surface.
2. Plug the mains lead into the AC mains socket located towards the rear of the unit ensuring that the plug is pushed fully into the socket.
3. Plug the other end into a mains wall socket and switch on.

**IMPORTANT:** The mains plug is used as the means of connecting the radio to the mains supply. The mains socket used for the radio must remain accessible during normal use. In order to disconnect the radio from the mains completely, the mains plug should be removed from the mains socket outlet completely.

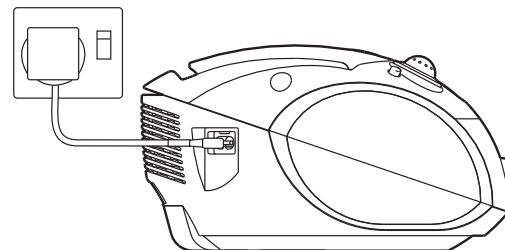

## Operating your radio FM - search tuning

1. Switch on your MP3 CD radio by rotating the **Function** switch to the 'Radio' position. The **On indicator** will light.
2. Press the **Waveband** button to select the 'FM' waveband. The FM symbol will appear in the display.
3. The **Telescopic aerial** which is only operational on FM, should be fully extended and positioned for optimum reception.
4. Press and hold the **Tuning Up** or **Down** buttons in for a couple of seconds. Your radio will search in an upwards or downwards direction and stops automatically when it finds a station of sufficient strength. Search tuning may be stopped by a single press on either the **Tuning Up** or **Down** buttons.
5. Adjust the volume by rotating the **Volume** control to the required level.
6. To receive stereo broadcasts set the **FM Mode** switch located on the rear of the unit to the 'FM Stereo' position. The **FM stereo indicator**  $\infty$  will be displayed. If the station being received is weak some hiss may be audible, to reduce the hiss set the FM Mode switch to the 'FM mono' position to return to mono operation.
7. Press the **DBB** button to activate the Deep Bass Boost system. Press the **DBB** button again to deactivate the Deep Bass Boost system.
8. The radio can be switched off by rotating the **Function** switch to the 'Off' position.

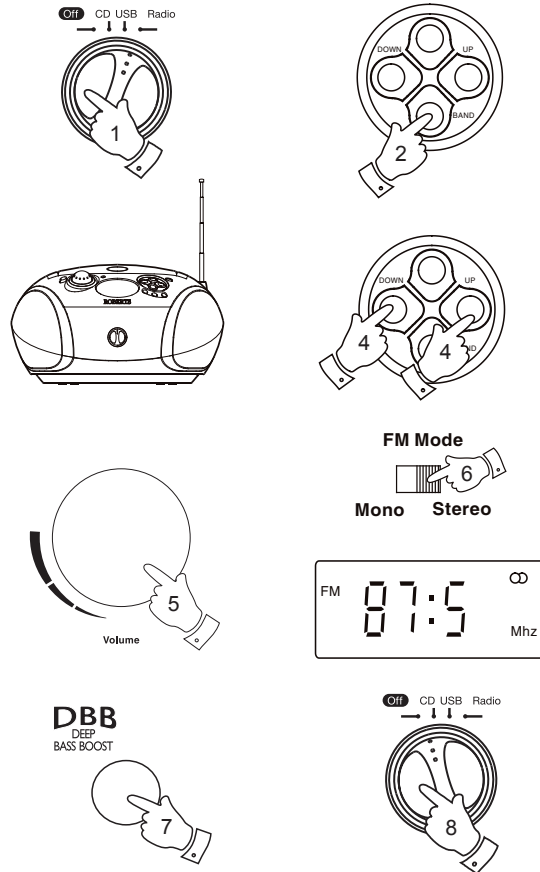

## Operating your radio MW - search tuning

1. Switch on your MP3 CD radio by rotating the **Function** switch to the 'Radio' position. The **On indicator** will light.
2. Press the **Waveband** button to select the 'MW' waveband. The MW symbol will appear in the display.

3. To auto-tune press and hold the **Tuning Up** or **Down** buttons in for a couple of seconds. Your radio will search in an upwards or downwards direction and stops automatically when it finds a station of sufficient strength.

Search tuning may be stopped by a single press on either the **Tuning Up** or **Down** buttons.

For MW reception there is a built in ferrite aerial. Rotate the unit to the position giving best reception.

4. Adjust the volume by rotating the **Volume** control to the required level.
5. Press the **DBB** button to activate the Deep Bass Boost system. Press the **DBB** button again to deactivate the Bass Boost system.
6. The radio can be switched off by rotating the **Function** switch to the 'Off' position.

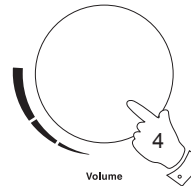
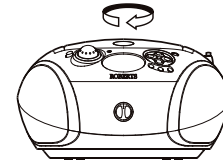
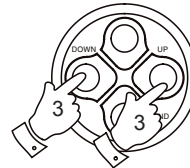
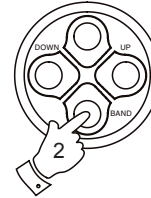

**DBB**  
DEEP  
BASS BOOST





## Operating your radio - manual tuning

1. Switch on your MP3 CD radio by rotating the **Function** switch to the 'Radio' position. The **On indicator** will light.
2. Press the **Waveband** button to select either the 'FM' or 'MW' waveband. The band symbol will appear in the display. On FM fully extend the telescopic aerial. On MW rotate your radio for best reception.
3. A single press on either the **Tuning Up** or **Down** buttons will change the frequency up or down. The frequency steps are:- FM 50MHz, MW 9kHz.
4. Adjust the volume by rotating the **Volume** control to the required level.
5. Press the **DBB** button to activate the Deep Bass Boost system. Press the **DBB** button again to deactivate the Bass Boost system.
6. The radio can be switched off by rotating the **Function** switch to the 'Off' position.

Off CD USB Radio

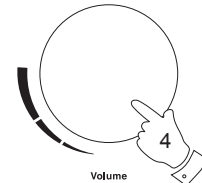
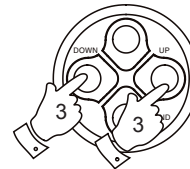
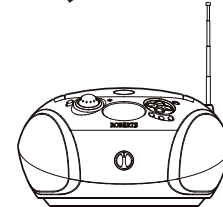
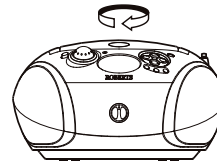
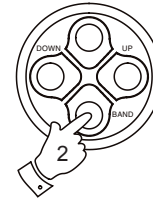

**DBB**  
DEEP  
BASS BOOST



Off CD USB Radio



## Presetting radio stations - automatically

1. Switch on your MP3 CD radio by rotating the **Function** switch to the 'Radio' position. The **On indicator** will light.
2. Press the **Waveband** button to select either the 'FM' or 'MW' waveband. The band symbol will appear in the display. On FM fully extend the telescopic aerial. On MW rotate your radio for best reception.
3. Press and hold the **Programme Memory** button in for several seconds. The memory symbol will flash on the display whilst it is searching. The radio searches for up to 10 radio stations and then stores them automatically in preset positions 1 - 10 and the memory symbol remains on the display.
4. After all ten preset positions have been stored the radio will begin to play the station located in the preset 1 position.

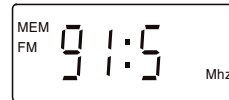
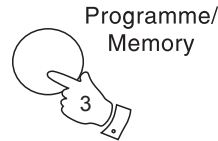
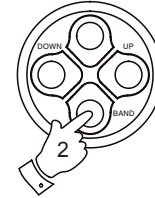

## Presetting radio stations - manually

Up to 10 stations on the FM band and the MW band can be stored in the preset positions.

1. Switch on your MP3 CD radio by rotating the **Function** switch to the 'Radio' position. The **On indicator** will light.
2. Press the **Waveband** button to select either the 'FM' or 'MW' waveband. The band symbol will appear in the display.
3. Press the **Tuning Up** or **Down** buttons to select desired radio station.
4. Press and release the **Programme Memory** button to activate the memory function. The memory symbol 'MEM' will appear on the display.
5. Whilst 'MEM' is flashing, press the **Memory Up** or **Down** buttons to select the preset number position where you want to store the station.
6. Press and release the **Programme Memory** button to store the station. The preset number will now appear alongside 'MEM' in the display.
7. Repeat the above procedure for the remaining presets.
8. The radio can be switched off by rotating the **Function** switch to the 'Off' position.

**Note:** Pre-setting of stations can only be carried out whilst 'MEM' is flashing in the display.

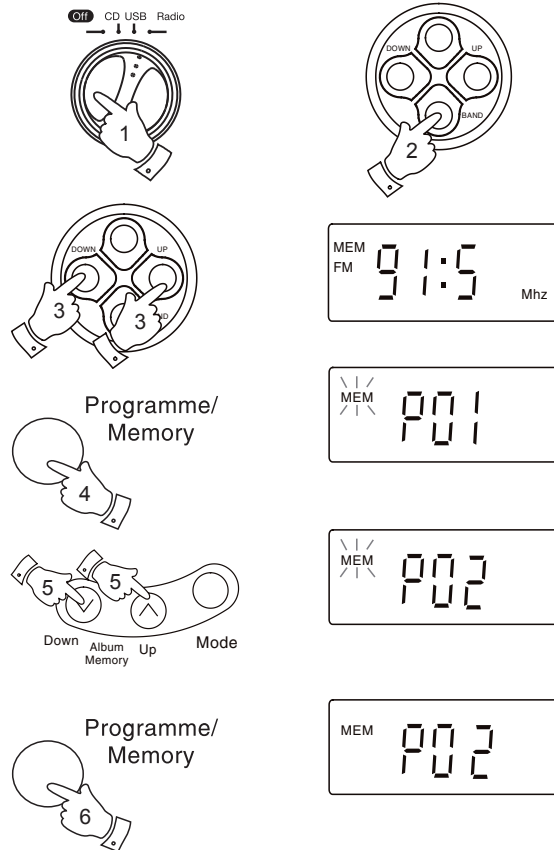

## Recalling a preset station

1. Switch on your MP3 CD radio by rotating the **Function** switch to the 'Radio' position. The **On indicator** will light.
2. Press the **Waveband** button to select either the 'FM' or 'MW' waveband. The band symbol will appear in the display.
3. Press the **Memory Up** or **Down** buttons to recall the stored preset station. Use **Memory Up** or **Down** buttons to step through the available stations.

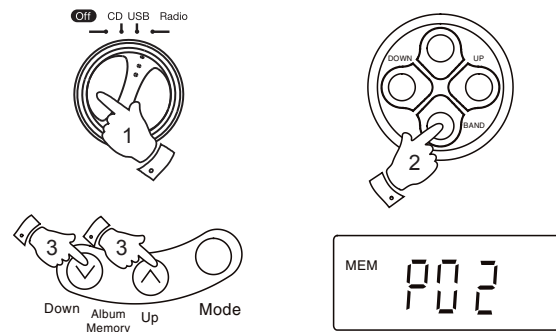

## Last station memory

1. Your MP3 CD Radio provides an automatic last station memory function. This function recalls the station that was playing when the radio was switched off.

## Compact discs

Use only Digital Audio CDs which have the  symbol.

Never write on a CD or attach any sticker to the CD. Always hold the CD at the edge and store it in its box after use with the label facing up.

To remove dust and dirt, breathe on the CD and wipe it with a soft, lint free cloth in a straight line from the centre towards the edge.

Cleaning agents may damage the CD.

Do not expose the CD to rain, moisture, sand, or to excessive heat. (e.g. from heating equipment or in motor cars parked in the sun).

## CD-R/CD-RW discs

Your MP3 CD radio can playback CD-DA format audio CD-R/CD-RW discs that have been finalised\* upon completion of recording.

Your MP3 CD radio may fail to playback some CD-R/CD-RW discs due to poor recording and a wide variation in quality of the CD-R/CD-RW disc.

\*Finalising enables a CD-R/CD-RW disc to playback on audio CD players such as your Swallow 2.

**Note:** If the unit is in the CD stop mode position for more than 15 minutes it will automatically switch to the standby mode. The operation indicator and the LCD will go off in such a case. To use the unit again switch on the unit.

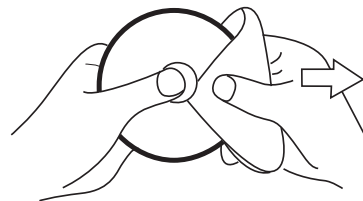

## Warning

**CLASS 1 LASER PRODUCT** means that the laser's construction makes it inherently safe so that the legally prescribed maximum permissible radiation values can never be exceeded.

**Caution:** Using any equipment or devices other than those described and specified in these operating instructions, or tampering with the unit in any way, can result in dangerous exposure to radiation.



## Inserting a CD

1. Rotate the **Function** switch to the 'CD' position. The **On indicator** will light. If you select a CD and have not inserted a CD, '---' will appear on the display.
2. To open the cd compartment, press and release the **Open/Close** button on the top panel, front right hand corner.
3. Insert an audio CD, printed side facing up. Press the CD onto the spindle until it clicks into place and gently close the CD compartment by pushing the **Open/Close** button on the top panel, front right hand corner. The CD player will scan the contents of the CD and the total number of tracks will appear on the display.

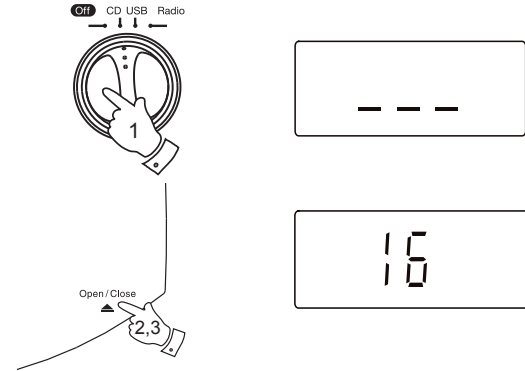

## Playing a CD

1. Press the **Play/Pause** button to start playback. The display will show the track number.
2. Set the **Volume** and press the **Deep bass boost** button to the required settings.
3. To pause playback press the **Play/Pause** button. To resume playback press the **Play/Pause** button again.
4. To stop playback, press the **Stop** button. The total number of CD tracks will be displayed.
5. To take out the CD, open the CD compartment. Press and release the **Open/Close** button on the top panel, front right hand corner. The CD door should open when the CD is in stop mode.

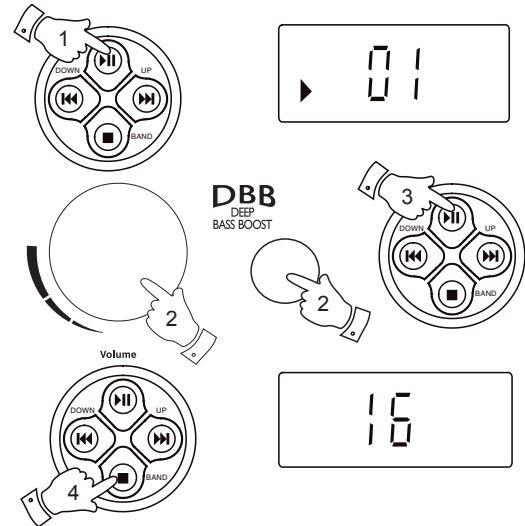

## Selecting a track

1. Whilst the CD is playing, press either the **F. Skip** or **B. Skip** buttons to change to the desired track, the track number appears in the display.
2. You can also skip tracks when the player is in stop mode. Skip to the desired track using the **F. Skip** or **B. Skip** buttons.
3. Press the **Play/Pause** button to play the selected track.

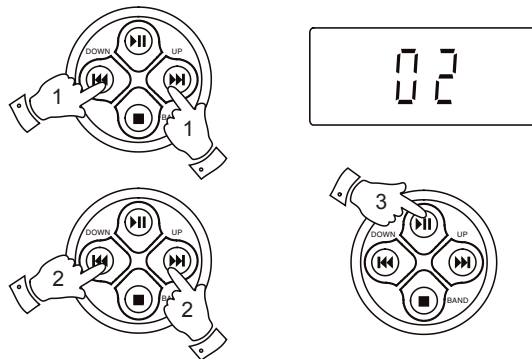

---

## Search function

1. Whilst the CD is playing, press and hold the **F. Skip** or **B. Skip** buttons.
2. Release the button when the desired part of the track is reached.

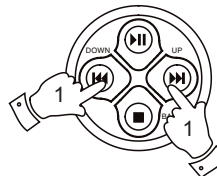

## CD repeat mode

1. Whilst the CD is playing, press the **Mode** button once. The current track is repeated.
2. Press the **Mode** button again to repeat all tracks on the cd. The repeat 'All' indicator will show in the display.
3. Press the **Mode** button again to return to normal play. The repeat indicator will disappear.

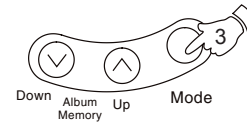
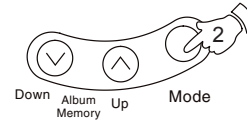
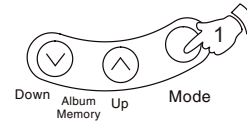

## CD random mode

1. Whilst the CD is in stop mode, repeatedly press the **Mode** button until the random indicator 'RND' appears in the display.
2. Press the **Play/Pause** button to begin random playback. All tracks on the CD will be played back once in random order.
3. To stop random playback, press the **Mode** button again.

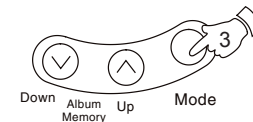
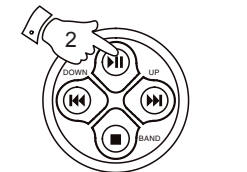
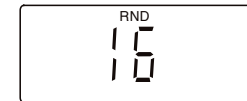
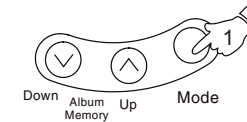



## Programmed play

By programming the player you can play up to 20 tracks in any desired order.

1. Whilst the CD is in Stop mode, press and release the **Programme/Memory** button. The display will flash 'P01' and 'MEM' flashes on the display.
2. Select the first track using the **F. Skip** or **B. Skip** buttons. The track number will show on display.
3. To store this track press and release the **Programme/Memory** button. The display will flash ('P02') and 'MEM' will flash on the display.
4. Repeat the above steps until you have completed your programme (maximum 20 tracks). Press the **Play/Pause** button to commence play of selected tracks.
5. To stop the playback, press the **Stop** button. The display will show the total number of tracks.
6. To resume programme play press and release the **Programme/Memory** button. and then press the **Play/Pause** button. The display will show the programmed track.

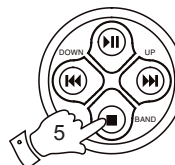
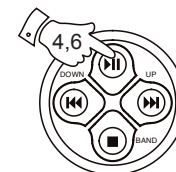
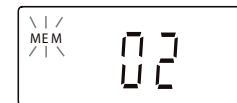
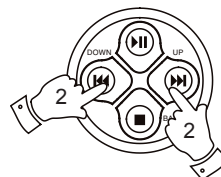

## Editing a programme

1. Whilst the CD is in Stop mode, repeatedly press and release the **Programme/Memory** button to step through the tracks programmed until you find the desired track number. The display will show the track number e.g. ('02') once and 'MEM' will flash.

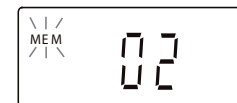

2. Select a new track using the **F. Skip** or **B. Skip** buttons. The track number will show on the display.
3. To store the track press and release the **Programme/Memory** button. The display will show the selected track number ('16'). The new track has been stored in the programme.
4. Press the **Play/Pause** button to play the revised programme tracks.

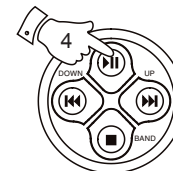
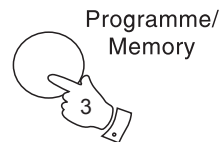
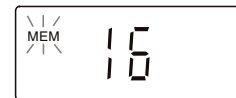
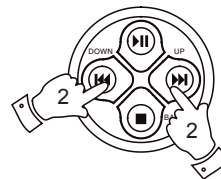

## Checking a programme

1. Whilst the CD is in Stop mode, repeatedly press and release the **Programme/Memory** button to step through the tracks programmed. The display will show each programmed track number in sequence.
2. Resume play by pressing the **Play/Pause** button.

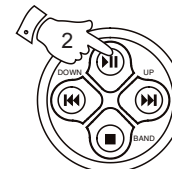

## Erasing a programme

1. Whilst the CD is in Stop mode, open the CD door to erase the programme. Programmes are also erased by changing position of the **Function** switch to 'Off' or to the 'Radio' position.
- Alternatively, whilst programming press the **Stop** button as needed.

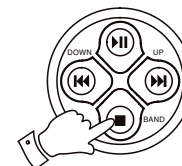
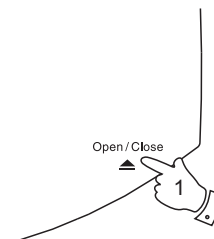

## MP3/WMA Mode

The Swallow 2 is able to play CD-R and CD-RW discs containing MP3/WMA files. Files must be created at a sampling frequency of 44.1 kHz.

In MP3/WMA mode the terms 'album' and 'file' are very important. 'Album' corresponds to a folder on a PC, 'File' to a PC or a CD-DA track. The device reads MP3/WMA files with a maximum of 255 files per album. An MP3/WMA CD may not contain more than 512 files or albums in total.

The device sorts albums, or the files on an album, by name into alphabetical order. If you wish to order them differently, change the name of the file or album and put a number before the name.

When burning CD-R and CD-RWs with audio files, various problems may arise which could lead to interference in playback. This can be caused by faulty software or hardware settings or by the CD being used. Should such problems arise, contact the customer services of your CD burner or software manufacturer or look for relevant information, for example on the internet. When you are making audio CDs, observe all legal guidelines and ensure that the copyright of third parties is not infringed.

## Playing an MP3/WMA CD

- 1 Follow steps for inserting a CD previously. The display will show the album number.
2. Press the **Play/Pause** button to start playback. The display will show the track number.
3. Set the **Volume** and press the **Deep bass boost** button to the required settings.
4. To pause playback press the **Play/Pause** button. To resume playback press the **Play/Pause** button again.
5. To stop playback, press the **Stop** button. The total number of albums will be displayed.
6. To take out the CD, open the door by pressing on the edge marked **Open/Close**. The CD door should only be opened when the CD is in stop mode.

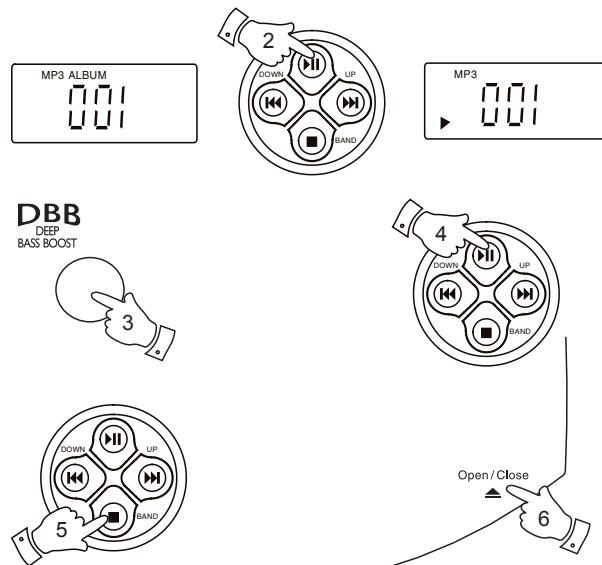

## Selecting albums and files

1. Select the album during playback by pressing the **Album/Memory Down** or **Up** button.
2. Select the file you want by pressing **F. Skip** or **B. Skip** buttons. Playback of the selected file starts automatically after a short time.
3. **Note:** You can also select albums and files in the stop position. However, you must then start playback of the file using the **Play/pause** button. The root album is shown as number '1'. However, you can only select an album if it actually contains MP3/WMA files.

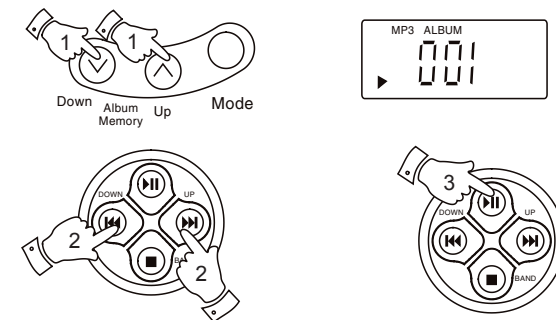

## Repeating a file (Repeat 1 file)

1. During playback, press the **Mode** button until the repeat indicator appears on the display.
2. To stop the function, press the **Mode** button until the repeat indicator disappears.

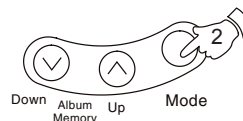
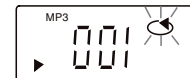
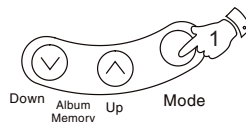

---

## Repeating all files in an album (Repeat album)

1. During playback press the **Mode** button twice. All the files on the current album are played back.
2. To stop the function, press the **Mode** button until the repeat indicator disappears.

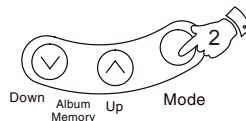
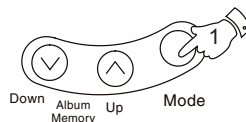

---

## Repeating all files (Repeat all)

1. During playback press the **Mode** button until the 'ALL' indicator appears in the display. The whole CD is played back.
2. To stop the function, press the **Mode** button until the repeat indicator disappears.

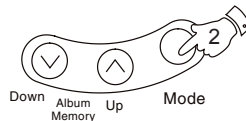
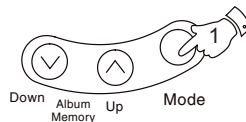

## Playing back files in random order

1. In Stop mode, press the **Mode** button until 'RND' appears in the display.
2. Press the **Play/Pause** button to start random playback. All files on the CD are played back once in random order.
3. To stop the function, press the **Mode** button until the random indicator disappears.

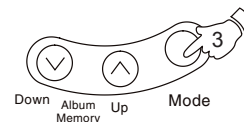
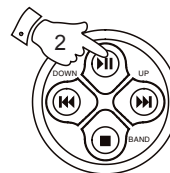
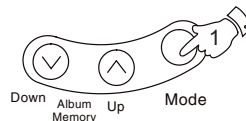

## Programming tracks

You can store and then playback up to 20 titles from various albums on the disc in a set order. A file may be stored more than once.

1. Whilst the CD is in stop mode press and release the **Programme/Memory** button. The display will show 'P01' for the first preset position. 'MEM' will flash on the display.
2. Select the album by pressing the **Album Memory Up** or **Down** buttons.
3. Select the file you want by pressing the **F Skip** or **B Skip** buttons.
4. Press and release the **Programme/Memory** button to save the file. The display will show 'P02' for the second preset position and 'MEM' will flash on the display.
5. To save more files repeat steps 2 to 4 above.

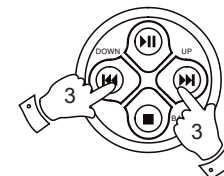
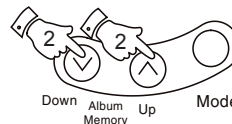

## Playing a programmed track

1. Start programmed play by pressing the **Play/Pause** button. Playback begins with the first programmed file.
2. To stop playback press the **Stop** button.
3. To play the programmed track again press the **Programme/Memory** button and then **Play/Pause** button.

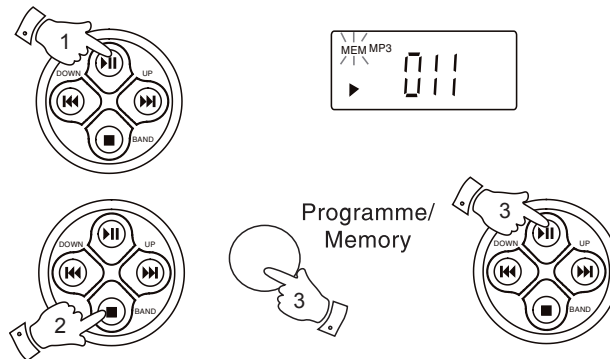

## Editing a programme

1. In Stop mode, repeatedly press and release the **Programme/Memory** button until the file number you require appears in the display.
2. Select the number of the new folder by pressing the **Album/Memory Down** or **Up** buttons.
3. Select the number of the new file or track by pressing the **F. Skip** or **B. Skip Up** buttons.
4. Press and release the **Programme/Memory** button to store the new file.

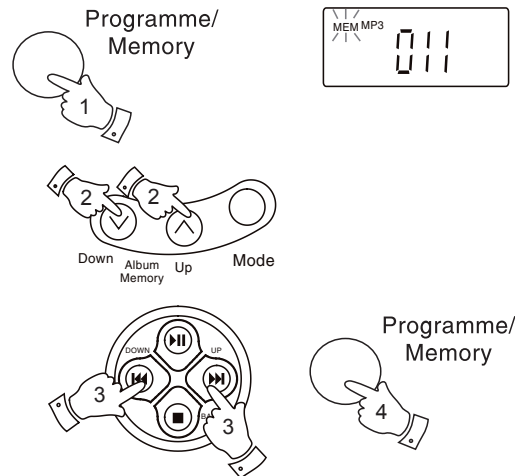

## Adding a new file

1. In Stop mode, repeatedly press and release the **Programme/Memory** button to step through the tracks programmed until you find the desired track number. The display will show the track number once and 'MEM' will flash.
2. Select the number of the new folder by pressing the **Album/Memory Down** or **Up** buttons.
3. Select the number of the new file or track by pressing the **F. Skip** or **B. Skip** buttons.
4. Press and release the **Programme/Memory** button to store the file.

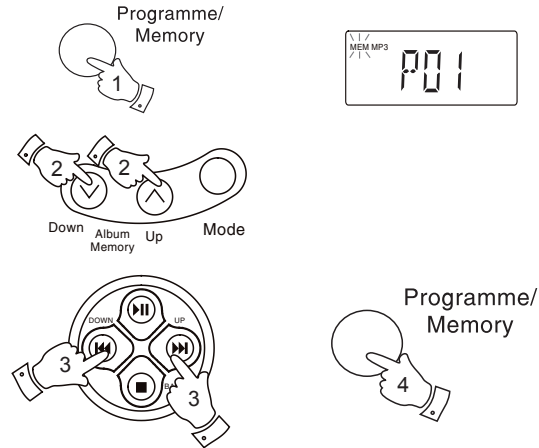



## USB mode

This section describes how to use your radio to access and playback your audio files via USB memory devices.

The Swallow 2 has been tested with a range of USB memory devices up to 32GB. However there are many different USB memory devices available and not all devices can be guaranteed to work in the Swallow 2. Memory must use the FAT or FAT 32 filing system in order to operate in the unit.

**Important:** *Your radio is designed to work with USB flash memory devices. It is not intended to be connected to hard disk drives or any other type of USB device.*

Audio formats supported for playback are MP3 and WMA. Playback does not support files encoded using WMA lossless, WMA voice, WMA 10 professional, nor files of any format which have DRM protection.

The USB socket is located on the rear right hand side of the radio.

## Inserting and removing a USB memory device

1. Carefully insert a USB memory device into the USB socket. To remove the USB memory device simply pull the device out.

## Cautions

In order to minimise the risk of damage to your radio or USB memory device, please place the unit so that the device cannot be easily knocked while it is inserted in the socket.

Remove the USB memory device before carrying the unit or if not using the USB feature for a prolonged period.

Switch the unit off before removing your USB memory device.

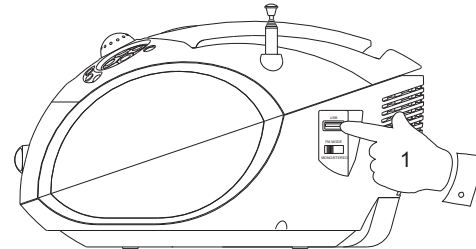

## Selecting USB mode

1. To select the USB mode slide the **Function** switch to *the 'USB'* position.

**Note:** Playback control in USB mode is similar to CD-MP3/WMA mode (see pages 18-23). MP3 and WMA files are played back in the order that they are written to the USB memory device by your computer except when random mode is used.

**Note:** The USB memory device should not be removed during playback as damage or corruption of files may occur.

**Note:** If the unit is in the USB stop mode position for more than 15 minutes it will automatically switch to the standby mode. The operation indicator and the LCD will go off in such a case. To use the unit again switch on the unit.



## General

Do not allow this radio to be exposed to water, steam or sand. Do not leave your radio where excessive heat could cause damage such as in a parked car where the heat from the sun can build up even though the outside temperature may not seem too high. It is recommended that the FM band be used wherever possible as better results in terms of quality and freedom from interference will usually be obtained than on the MW band.



- No objects filled with liquids such as vases, shall be placed on the radio.
- It is recommended to operate the product such that there is a minimum distance (10cm recommended) to adjacent objects in order to ensure good ventilation.
- The ventilation of the product should not be restricted by covering it or its ventilation openings with items such as newspapers, table-cloths, curtains etc.
- No naked flame sources such as lighted candles should be placed on the product.
- It is recommended to avoid using or storing the product at extremes of temperature. Avoid leaving the unit in cars, on window sills in direct sunlight etc.

## Mains supply

The Swallow 2 will operate from a supply of AC 230 volts, 50Hz  $\sim$  only.

**DO NOT cut off the mains plug from this equipment.** If the plug fitted is not suitable for the power points in your home or the cable is too short to reach a power point, then obtain an appropriate safety approved extension lead or adaptor. If in doubt consult your dealer.

If nonetheless the mains plug is cut off, remove the fuse and dispose of the plug immediately to avoid a possible shock hazard by inadvertent connection to the mains supply.

If this product is not supplied with a mains plug, or one has to be fitted, then follow the instructions given below:

**IMPORTANT. DO NOT** make any connection to the larger terminal which is marked with the letter E or by the safety earth symbol  $\perp$  or coloured Green or Green-and-yellow.

The wires in the mains lead are coloured in accordance with the following codes :-

BLUE - NEUTRAL

BROWN - LIVE

The wire coloured BLUE must be connected to the terminal marked N or coloured BLACK.

The wire coloured BROWN must be connected to the terminal marked L or coloured RED.

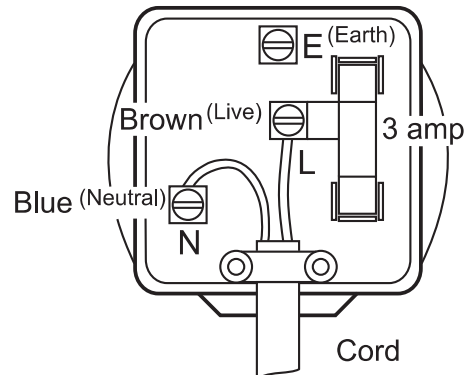

## Fuse

When replacing the fuse only a 3A ASTA approved to BS1362 type should be used and be sure to re-fit the fuse cover.

IF IN DOUBT - CONSULT A QUALIFIED ELECTRICIAN.

## Underneath

The nameplate is located on the underside of your CD radio.

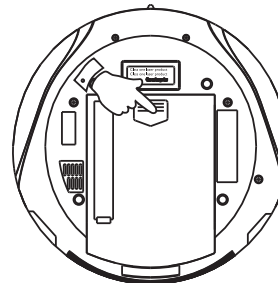

---

## Headphones

A 3.5mm Headphone socket located on the left side of the unit is provided for use with either headphones or an earpiece. Inserting a plug into the socket automatically mutes the internal loudspeaker.

Please be aware that the sensitivity of headphones can vary widely. We therefore recommend setting the volume to a low level before connecting headphones to the radio.

**IMPORTANT:** Excessive sound pressure from earphones and headphones can cause hearing loss.

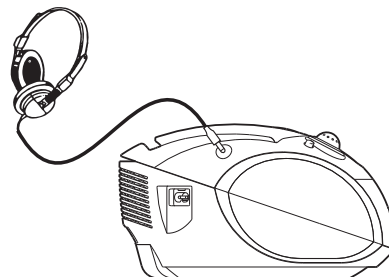

To prevent possible hearing damage, do not listen at high volume levels for long periods.

## Specification

### Power Requirements

Mains	AC 230 volts, 50Hz  only
Batteries	6 x LR14 (C size)
Headphone socket	3.5mm diameter

### Frequency Coverage

FM	87.5 - 108MHz
MW	522 - 1620 kHz

### MP3/WMA features

Playback format	MPEG 1 layer 3 (MP3)
Sampling frequency	44.1 kHz
File system/file management	ISO 9660 Level 1 compatible

*The Company reserves the right to amend the specification without notice.*

## Circuit features

Output power	2 x 1 Watt	
Aerial System	FM	Telescopic aerial
	MW	Built-in Ferrite bar aerial

---

## Troubleshooting

In case of malfunction due to electrostatic discharge, it may be necessary to reset the product to resume normal operation. This may generally be performed by turning the unit off and on. In some cases a more complete reset may be needed, by removing all sources of power (battery and mains) when turned off.

## Guarantee

This product is guaranteed for twelve months from the date of purchase by the original owner against failure due to faulty workmanship or component breakdown, subject to the procedure stated below. Should any component or part fail during this guarantee period it will be repaired or replaced free of charge.

The guarantee does not cover:

1. Damage resulting from incorrect use.
2. Consequential damage.
3. Product with removed or defaced serial numbers.

N.B. Damaged or broken telescopic aerials will not be replaced under guarantee.

Procedure:

Any claim under this guarantee should be made through the dealer from whom the product was purchased. It is likely that your Roberts dealer will be able to attend to any defect quickly and efficiently, but should it be necessary the dealer will return the product to the company's service department for attention. In the event that it is not possible to return the product to the Roberts dealer from whom it was purchased, please contact Roberts Radio using the contact details on the [www.robertsradio.com](http://www.robertsradio.com) website.

For product repairs falling outside the guarantee period, please refer to the "customer care" tab on the [www.robertsradio.com](http://www.robertsradio.com) website.

*These statements do not affect the statutory rights of a consumer.*



Issue 5

## **ROBERTS RADIO LIMITED**

PO Box 130  
Mexborough  
South Yorkshire  
S64 8YT

Website: <http://www.robertsradio.com>

© 2005, 2014 Roberts Radio Limited

