

ROBERTS

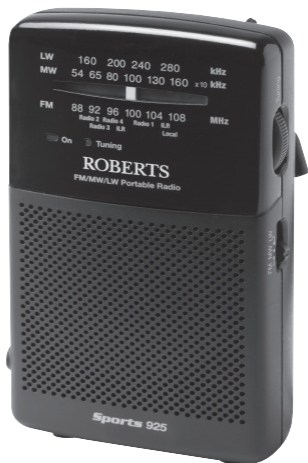

Sports 925

3-band battery portable radio

Please read this manual before use

Controls

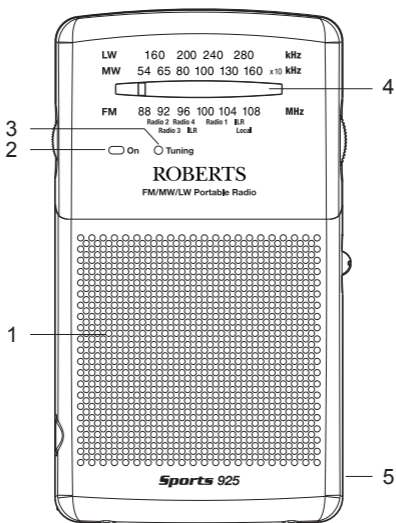

Controls

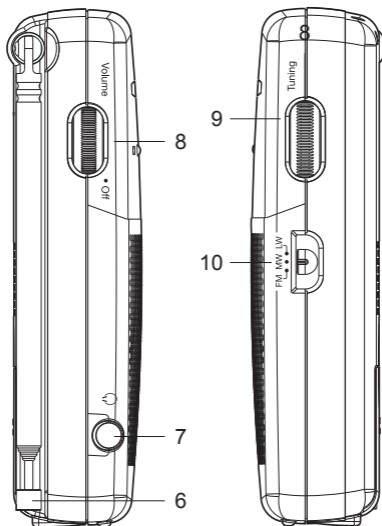

6. Telescopic aerial
7. Headphone socket
8. Volume On/Off control
9. Tuning control
10. Waveband switch

Inserting batteries

1. Open the **battery cover** on the rear of your radio by sliding the cover in the direction of the arrow.
2. Insert two LR6 (AA size) batteries into the spaces in the compartment. Take care to ensure all batteries are inserted with the correct polarity as shown. Close the battery cover.
3. Reduced power, distortion and a stuttering sound are all signs that the batteries may need replacing.
4. If the radio is not to be used for an extended period of time it is recommended that the batteries are removed from the radio.

Important: The batteries should not be exposed to excessive heat such as sunshine, fire or the like. After use, disposable batteries should if possible be taken to a suitable recycling centre. On no account should batteries be disposed of by incineration.

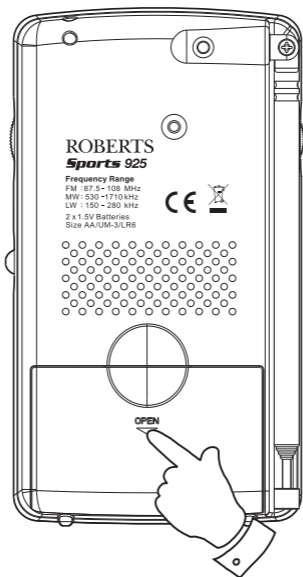

Operating your radio

1. Switch on your radio by rotating the **Volume control** clockwise until a click is heard. The **Power indicator** will appear.
2. Set the **Waveband switch** to the required waveband.
3. Adjust the **Volume control** until a hissing sound is heard.
4. Rotate the **Tuning control** to select the desired station. The **Tuning indicator** will light when the station is correctly tuned. On MW and LW the tuning scale is marked in kilohertz (kHz). On FM the tuning scale is marked in Megahertz (MHz).

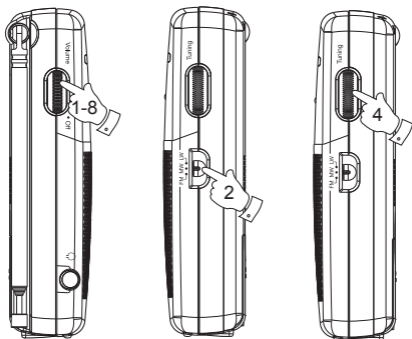

- For MW and LW reception rotate your radio to the position giving best reception.
- For FM reception fully extend the **Telescopic aerial** and then angle and rotate for best reception.
- Adjust the **Volume control** to the required sound level.
- To switch off your radio rotate the **Volume control** fully anticlockwise until a click is heard.

Note: The telescopic aerial is inoperative on MW and LW.

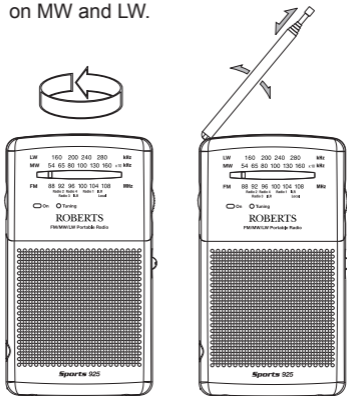

Headphones

A 3.5mm **headphone socket** located on the left hand side of your radio is provided for use with either headphones or an earpiece. Inserting a plug automatically mutes the internal loudspeaker. Please be aware that the sensitivity of headphones can vary widely. We therefore recommend setting the volume to a low level before connecting headphones to the radio. It is also recommended to reduce the volume before unplugging your headphones.

IMPORTANT: Excessive sound pressure from earphones and headphones can cause hearing loss.



To prevent possible hearing damage, do not listen at high volume levels for long periods.

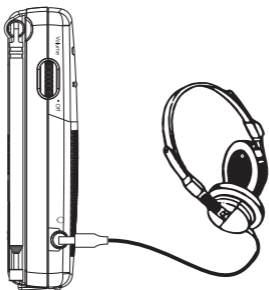

General

Do not allow this radio to be exposed to water, steam or sand. It is recommended to avoid using or storing the product at extremes of temperature. Avoid leaving the unit in cars, on window sills, in direct sunlight etc.

It is recommended that the FM band be used wherever possible as better results in terms of quality and freedom from interference will usually be obtained than on MW or LW bands.

The name plate is located on the rear of your radio.



Specifications

Batteries

2 x LR6 (AA size)

Battery life

Approx 60hrs of listening for 4 hours a day at normal volume using alkaline cells.

Frequency Coverage

FM 87.5-108MHz,

MW 530-1710kHz

LW 150-280kHz

Circuit Features

Loudspeaker 57mm

Output Power 50mW into 8 ohm

Headphone socket 3.5mm dia.

Aerial System

FM Telescopic aerial

MW Built-in Ferrite aerial

LW Built-in Ferrite aerial

The Company reserves the right to amend the specification without notice.

Guarantee

This product is guaranteed for twelve months from the date of purchase by the original owner against failure due to faulty workmanship or component breakdown, subject to the procedure stated below. Should any component or part fail during this guarantee period it will be repaired or replaced free of charge.

The guarantee does not cover: 1. Damage resulting from incorrect use. 2. Consequential damage. 3. Product with removed or defaced serial numbers. N.B. Damaged or broken telescopic aerials will not be replaced under guarantee.

Procedure: Any claim under this guarantee should be made through the dealer from whom the product was purchased. It is likely that your Roberts dealer will be able to attend to any defect quickly and efficiently, but should it be necessary the dealer will return the product to the company's service department for attention. In the event that it is not possible to return the product to the Roberts dealer from whom it was purchased, please contact Roberts Radio using the contact details on the www.robertsradio.com website.

For product repairs falling outside the guarantee period, please refer to the "customer care" tab on the www.robertsradio.com website.

These statements do not affect the statutory rights of a consumer.

ROBERTS RADIO LIMITED



PO Box 130
Mexborough
South Yorkshire
S64 8YT



Website: <http://www.robertsradio.com>

© 2010, 2014 Roberts Radio Limited

Issue 2