

ROBERTS

Sound for Generations

solarDAB

Solar powered DAB radio with rechargeable battery pack



DAB

Digital Audio Broadcasting

Please read this manual before use

Contents

<i>Controls</i>	2-3
<i>Using the AC adaptor</i>	4
<i>Using solar power</i>	5
<i>Operating your radio for the first time</i>	6-7
<i>Selecting a station</i>	8
<i>Secondary services</i>	8
<i>Display modes</i>	9
<i>Presetting stations</i>	10
<i>Recalling a preset</i>	10
<i>Finding new stations - in the UK</i>	11
<i>Finding new stations - outside the UK</i>	11
<i>Finding new stations - manual tuning</i>	12
<i>System reset</i>	13
<i>Headphone socket</i>	14
<i>Auxiliary input socket</i>	14
<i>Display backlight</i>	15
<i>Battery pack</i>	15
<i>General</i>	15
<i>Specifications</i>	16
<i>Circuit features</i>	16
<i>Notes</i>	17
<i>Guarantee</i>	18

Controls

(Front)

1. Tuning control
2. Volume control
3. On/Off button
4. Preset button
5. Mode Button
6. Telescopic aerial
7. Signal strength
8. Solar charging level
9. On charge indicator
10. Battery indicator
11. Info button
12. Scan button

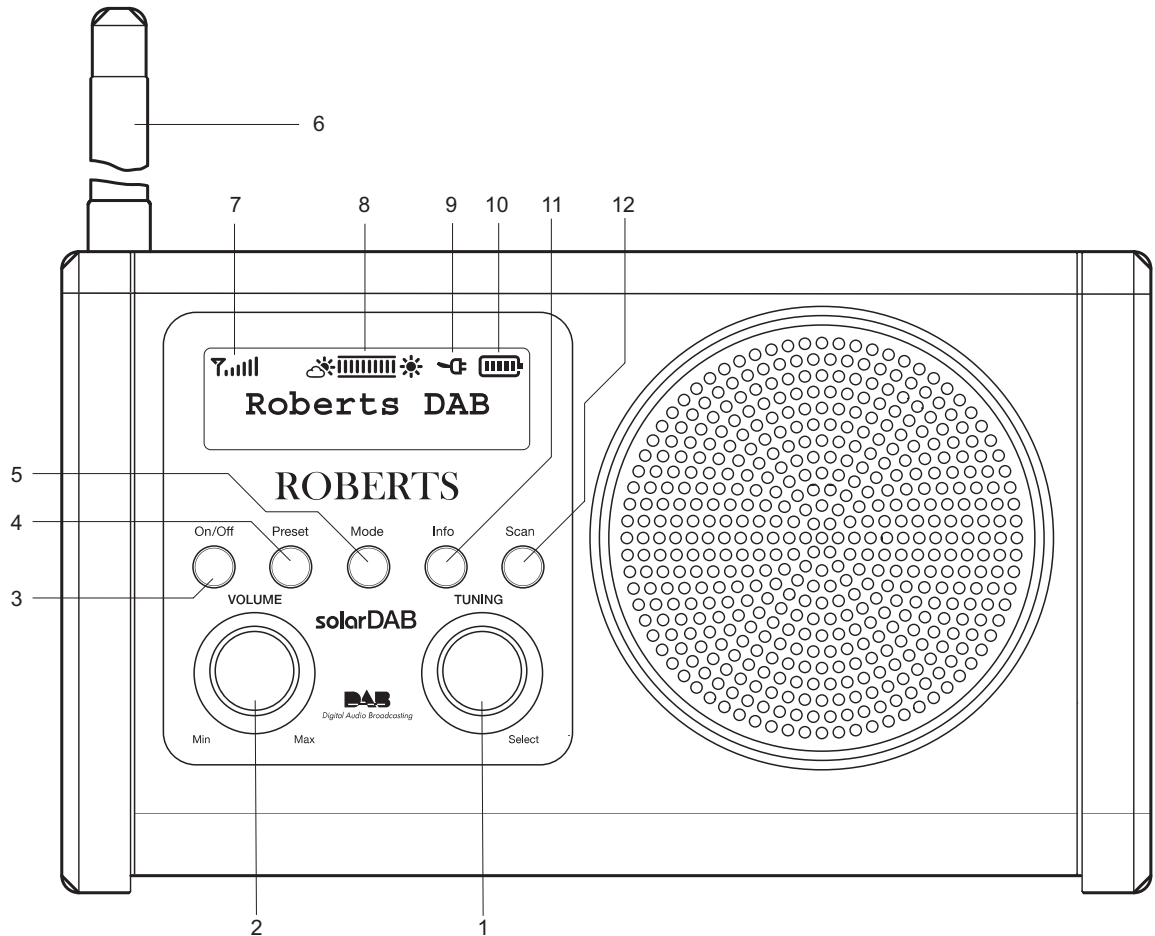

If you need any further advice, please call our Technical Helpline on :-
020 8758 0338 (Mon-Fri)

Controls

(Back)

- 13. DC input socket
- 14. Line in socket (aux-in)
- 15. Headphone socket
- 16. Aerial storage slot

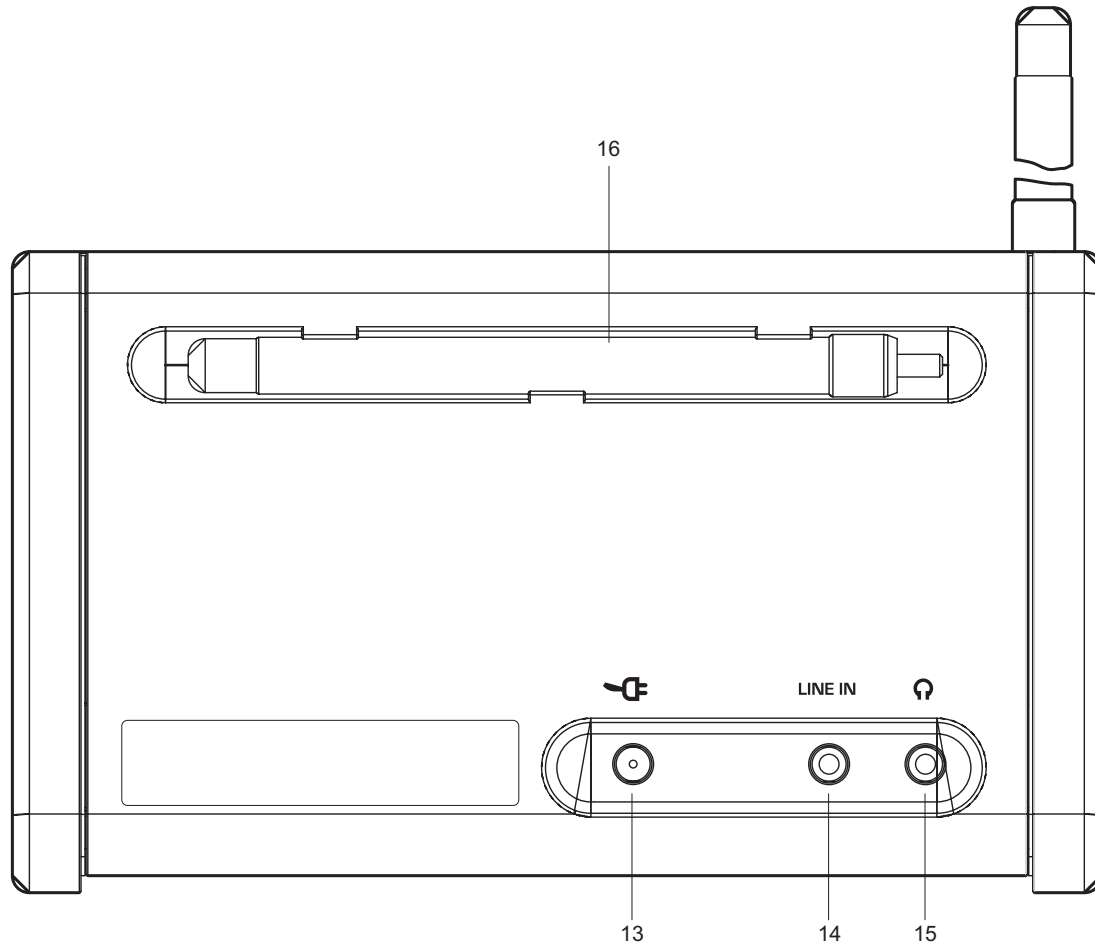

Using the AC adaptor

Your solarDAB radio may be powered either by using an AC adaptor (supplied) or by using solar power.

For prolonged life, the internal rechargeable NiMH battery pack requires an external conditioning charge of 24 hours prior to first use.

1. Place your radio on a flat surface.
2. Insert the adaptor plug into the DC socket located on the rear of your radio.
3. Plug the adaptor into a standard 13 amp mains socket outlet. The display will show the on charge indicator and the battery indicator will be animated.
4. When the batteries are fully charged, the battery indicator should show all segments without flashing. Remember to keep the adaptor connected for a period of 24 hours for the initial charge in order to ensure optimal conditioning of the batteries.

The AC adaptor should be disconnected from the mains supply and the radio when not in use.

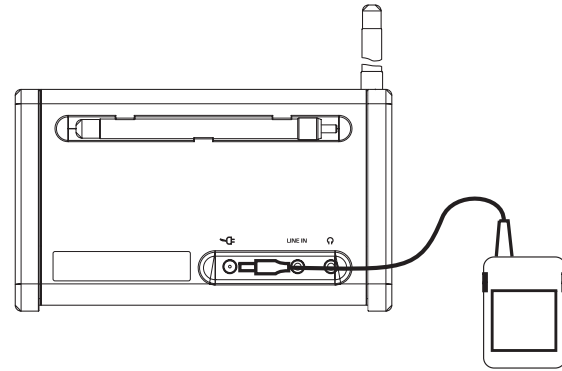

Note: The mains adaptor which is supplied with your radio is a high-efficiency type, designed to minimise energy consumption, whether the radio is playing, charging its batteries, or switched off (in standby). Do not use any other mains adaptor in place of the unit supplied. Such use will invalidate your guarantee.

*If you need any further advice, please call our Technical Helpline on :-
020 8758 0338 (Mon-Fri)*



IMPORTANT: The mains adaptor is used as the means of connecting the radio to the mains supply. The mains socket used for the radio must remain accessible during normal use. In order to disconnect the radio from the mains completely, the mains adaptor should be removed from the mains socket outlet completely.

Using solar power

1. In order to recharge your solarDAB radio's batteries using solar power, position the radio so that its integral solar panel receives direct sunlight. The more sunlight that falls on the solar panel - the more electricity it can generate to power the radio.
2. The solar charging level indicator  on the display should be used as a positioning aid to achieve the greatest output from the solar panel. It works on a bar system similar to the battery indicator.
3. If no bars or showing (or if the icon disappears completely) then there is no useful light available.
4. If less than half the available bars are showing, then there is some power from the solar panel which can supplement the batteries in operating the radio. The radio may be used and the batteries will last longer than if there was no solar assistance.
5. If more than half the available bars are showing then there is enough sunlight for the panel to operate the radio and simultaneously provide some charge to the battery pack.
6. If all of the bars are shown, then there is sufficient power from the solar panel to charge the battery and to power the radio at a moderate volume.
7. While it is possible for the solar panel to power the radio in the absence of the internal battery pack, the radio should not be used in this way. It is strongly recommended that the battery pack is ALWAYS installed when the radio is being used.
8. Keep the solar panel unobstructed and its protective lens free of dirt and grease. This will ensure best performance with the available sunlight.
9. The battery indicator  on the display gives an approximate indication of the amount of charge in the batteries. Note that directly after a period of charging, this battery indication may show more charge is available than is actually present and so the indicator should only be used as a rough guide.

NOTE: Best performance of the solar panel will be achieved when the sun is directly overhead, and the sunlight is unobstructed by clouds, foliage, curtains, and the like. In certain situations and poorer light conditions, the solar panel may not be effective and should not be relied upon as the primary energy source for standard usage. The solar panel is designed as a supplementary energy source which under suitable light conditions is able to contribute up to 100% of the radio's energy requirement.

The solar panel will only deliver power to the radio, or charge the batteries under natural sunlight. It will not deliver charge in artificial light.

Do NOT attempt to charge the batteries by placing the solar panel directly under any kind of sun-lamp. This will cause irreversible damage to the radio and may damage the casing.

Operating your radio for the first time

For prolonged life, the internal rechargeable NiMH battery pack requires an external conditioning charge of 24 hours prior to first use. Please see page 4.

1. Remove the aerial from its storage slot at the back of the radio and carefully screw it into its position on the top left of the radio. Carefully extend the telescopic aerial.
2. Press the **On/Off button** to switch on your radio. The display will light and will show the language options.
3. Scroll through the language options on the display by rotating the **Tuning control**.
4. Press the **Tuning control** to select the required language. The country option will then show on the display.
5. Scroll through country options on the display by rotating the **Tuning control**.
6. Press the **Tuning control** to select the required country. Your radio will automatically begin scanning for DAB radio stations.

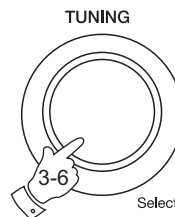
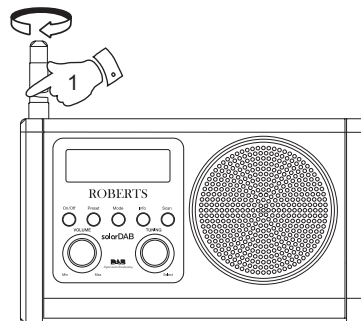

7. If this is the first time the radio is used a quick scan of UK Band 3 DAB channels will be carried out (or of the channels for the selected region, if different). The display will show "Auto tune Selected...".
8. As new stations are detected during autotune the station counter on the right hand side of the display will increase and stations will be added to the list.
9. When the autotune is completed the first station (in numeric-alpha order 0...9...A...Z) will be selected. If the radio has been used before then the last used station will be selected.
10. If the station list is still empty after the autotune your radio will display "No Signal".
11. If you see the "No Signal" message or if no DAB radio stations are found it may be necessary to relocate your radio to a position giving better reception. You should then press the **Scan button** to rescan for DAB radio stations.



When your radio has tuned to a station, the signal strength indicator  shows whether there is a strong or a weak signal present. Ideally, at least two bars should be showing for good reception.

Note: Your radio will remember the station last tuned to when you switch it off. In addition, if you were listening using the radio's auxiliary input, the radio will also remember that you were using it in that way. When you wish to listen to DAB radio again, press the **Mode button** to reselect DAB mode.

Selecting a station

1. The top line of the display shows the name of the station currently being listened to.
2. Rotate the **Tuning control** to scroll through the list of available stations. Note that the arrow pointer on the left side of the display shows the station that will be tuned to. This may be on the upper or lower line of the display depending on the direction of scrolling.
3. Press and release the **Tuning control** to select the desired station. The display may show "Tuning..." while your radio finds the new station.
4. Rotate the **Volume control** to the required setting.

Note: If after selecting a station the display shows "Not Available" it may be necessary to relocate your radio to a position giving better reception. The radio will attempt to re-tune to the previous radio station.

The use of the station presets for storing and selecting favourite radio stations is described on page 10.

Secondary services

1. Certain radio stations can have one or more secondary services associated with them. These are supplementary stations which a broadcaster may transmit at particular times, or for particular events - the BBC's Daily Service programme is an example.
2. The secondary service will appear in the list of available radio stations sorted alphabetically. Rotate and then press the **Tuning control** to select the desired station. At the end of the broadcast, the radio will automatically switch to the primary radio station for that service.

If you need any further advice, please call our Technical Helpline on :-
020 8758 0338 (Mon-Fri)

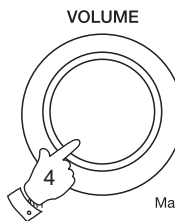
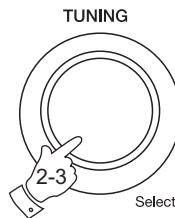

Display modes - DAB

Your radio has five display modes which can show information provided by the broadcaster in addition to the name of the radio station:-

1. Press the **Info button** to cycle through the various modes.

- a. Scrolling text Displays scrolling text messages such as artist, track name, phone in number etc.
- b. Multiplex Name Displays the name of DAB multiplex to which the current station belongs.
- c. Frequency Displays the frequency of the DAB multiplex for the station listened to.
- d. Bit rate & audio type Displays the digital bit rate & audio type for the station being listened to.
- e. Time Displays the current the time.



Presetting stations

There are 10 memory presets for the DAB waveband.

1. Press the **On/Off button** to switch on your radio and tune to the required station as previously described.
2. Press the **Preset button**. The display shows, either "Preset 1 free", or the name of the station already stored in Preset 1.
3. Rotate the **Tuning control** to choose from presets 1 to 10 and press and hold the **Tuning control**. Keep the control pressed while the station name flashes on the lower line of the display and release the control when the station name re-appears on the upper line of the display. The station will be stored under the chosen preset button. Repeat this procedure for the remaining presets as desired.
4. Stations stored in the presets may be overwritten by following the above procedure.

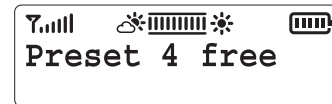
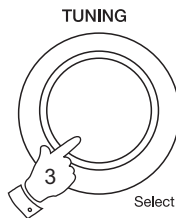
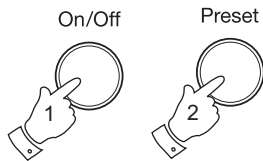

Recalling a preset

1. Press the **On/Off button** to switch on your radio.
2. Press the **Preset button**. The display shows, either "Preset 1 free", or the name of the station already stored in Preset 1.
3. Rotate the **Tuning control** to choose from presets 1 to 10.
4. Momentarily press the **Tuning button**. Your radio will then tune to the station stored in the preset memory.

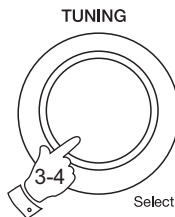
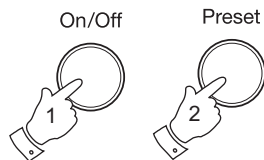

If you need any further advice, please call our Technical Helpline on :-
020 8758 0338 (Mon-Fri)

Finding new stations - in the UK

As time passes new stations may become available. To find new stations proceed as follows:-

1. Press and release the **Scan button**. The display will show "Auto tune selected". Your radio will perform a scan of the UK DAB frequencies. As new stations are found the station counter on the right-hand side of the display will increase and stations will be added to the list.



Finding new stations - outside the UK

If you are operating your radio in a country other than the UK you will need to follow these steps. In many countries DAB stations are located in frequency Band 3. Some countries use the L band frequencies either instead of or in addition to Band 3.

1. Press and hold the **Scan button**. The display will list the scan options available. These include some specific European countries. For other regions you will have the choice of Band 3 or L-band depending on the frequencies in use.
2. Either choose the **"Country"** option and then choose the required country, or rotate the **Tuning control** until **"DAB (all)"**, **"Band 3 (all)"** or **"L Band (all)"** is selected with the arrow on the display.
3. Press and release the **Tuning control**. Your radio will scan the selected band for available stations.

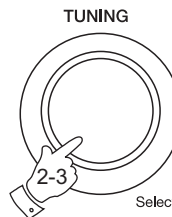

If you are uncertain regarding the frequencies used for DAB radio in your location, then select the **"DAB (all)"** option.

Finding new stations - manual tuning

Normally, you will use the auto tune feature as described above to find new radio stations. Should you need to search for DAB radio stations at a particular frequency, please use the following procedure.

1. Press and hold the **Scan button**. The display will list the scan options available.
2. Rotate the **Tuning control** until "**Band 3**" or "**L Band**" is selected with the arrow on the display, depending on which frequency band you wish to tune to.

3. Press and release the **Tuning control**. The display will then offer you a range of frequency blocks, named according to the DAB specifications

For Band 3, the frequency blocks are named 5A through 13F

For L Band, the frequency blocks are named LA through LW

4. Rotate the **Tuning control** until the desired frequency block is selected with the arrow on the display.
5. Press and release the **Tuning control** to initiate a scan of the selected frequency. If any new radio stations are found, then the reported number of services will increase, and the new radio stations will be added to the list stored in the radio.

After scanning, the radio will return to the radio station previously tuned.

If you are uncertain regarding the frequencies used for DAB radio in your location, then select the "**DAB (all)**" option.

*If you need any further advice, please call our Technical Helpline on :-
020 8758 0338 (Mon-Fri)*

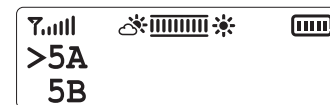
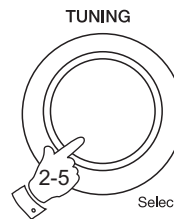

System reset

If your radio fails to operate correctly, or some digits on the display are missing or incomplete, or if you wish to restore your radio to its initial settings, please carry out the following procedure.

1. Press and hold down the **Info button**.
2. While keeping the **Info button** pressed, simultaneously rotate the **Tuning control** until the display shows "Reset?".
3. Rotate the **Tuning control** to Select either "Yes" to reset or "No" to return to normal tuning.
4. If you wish to perform the reset operation, rotate the **Tuning control** until "Yes" is selected and then press the **Tuning control** to confirm. A full reset of your radio will be performed. All presets and station lists will be erased.
5. After a system reset you will need to reselect the language and country settings. A scan of the required DAB band will then be performed.

Note: The number in the lower right of the display is a software version number and is provided purely for reference.

In case of malfunction due to electrostatic discharge, reset the product (reconnection of power source may be required) to resume normal operation.

If a problem persists our technical staff would be pleased to offer any assistance on operating the radio. Our technical helpline number is 020 8758 0338.

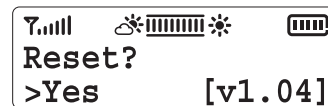
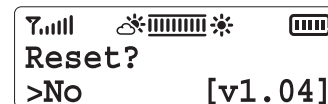
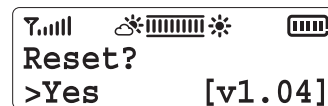
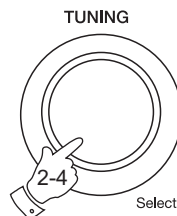

Headphone socket

A 3.5mm **Headphone Socket** located on the back of your radio is provided for use with either headphones or an earpiece. Inserting a plug automatically mutes the internal loudspeaker.

IMPORTANT: Excessive sound pressure from earphones and headphones can cause hearing loss.

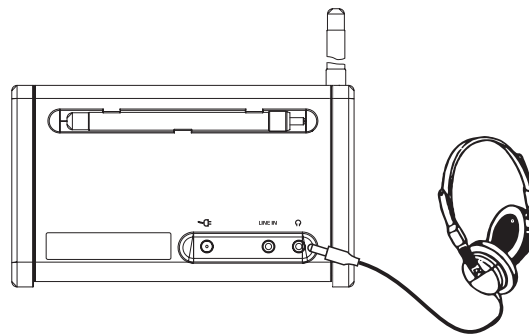

Auxiliary input socket

1. Connect a stereo or mono audio source (e.g. CD player, iPod, MP3 player) to the **Auxiliary input socket**.
2. Press the **Mode button** to select the auxiliary input. "Line in" will show on the display.
3. Adjust the **Volume control** for comfortable listening.
4. When you wish to listen to DAB radio again, press the **Mode button** to reselect DAB mode.

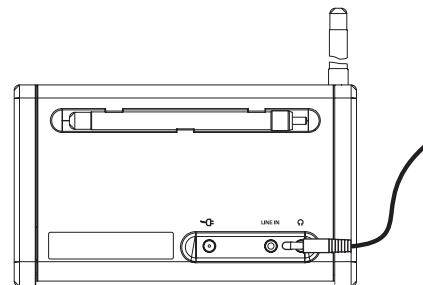

Display backlight

1. When running the radio on batteries (with or without solar assistance), the display backlight will be switched on for approximately 12 seconds when any button is pressed. Note that when the battery is almost exhausted, the radio will not switch on the backlight in order to conserve energy.
2. When your radio is powered by AC mains the display backlight will be switched on for approximately 3 minutes when any button is pressed.

Battery Pack

The battery pack which is built into your radio is designed to provide several years of service. When the batteries can no longer store sufficient energy to power your radio after having been charged they should be replaced.

Replacement battery packs will be available from Roberts Radio.

The old battery pack should be recycled or disposed of in an environmentally friendly way as prescribed by your local regulations.

General

Do not allow this radio to be exposed to water, steam or sand. Do not leave your radio where excessive heat could cause damage such as in a parked car where the heat from the sun can build up even though the outside temperature may not seem too high.

The name plate is located on the back of your radio.



- Your radio should not be exposed to dripping or splashing and that no objects filled with liquids, such as vases, shall be placed on the radio.
- It is recommended to operate the product such that there is a minimum distance (10cm recommended) to adjacent objects in order to ensure good ventilation.
- The ventilation of the product should not be restricted by covering it or its ventilation openings with items such as newspapers, tablecloths, curtains etc.
- No naked flame sources such as lighted candles should be placed on the product.
- It is recommended to avoid using or storing the product at extremes of temperature. Avoid leaving the unit in cars in direct sunlight.

Note that normal use of the solar panel by placing the radio in the sun on a windowsill, in a conservatory or in a similar location is intended and should not harm your radio.

Specifications

Power Requirements

Mains	AC 230 volts, 50Hz  only (adaptor)
Batteries	Built in NiMH 3 x AA cell battery pack

Battery Life Up to 27 hours on full charge at moderate volume

Solar Power Continuous play under adequate sunlight

Frequency Coverage

DAB Band 3	174.928 - 239.200MHz
DAB L-band	1452 - 1492MHz

Circuit Features

Loudspeaker 80mm

Output Power 1W

Headphones Stereo, 3.5mm diameter socket

Aerial System: DAB Band 3 Telescopic aerial
DAB L-band Internal aerial

The Company reserves the right to amend the specification without notice

Notes

A series of 20 horizontal dotted lines for writing notes.

Guarantee

This instrument is guaranteed for twelve months from the date of delivery to the original owner against failure due to faulty workmanship or component breakdown, subject to the procedure stated below. Should any component or part fail during this guarantee period it will be repaired or replaced free of charge.

The guarantee does not cover:

1. Damage resulting from incorrect use.
2. Consequential damage.
3. Receivers with removed or defaced serial numbers.

N.B. Damaged or broken telescopic aerials will not be replaced under guarantee.

Procedure:

Any claim under this guarantee should be made through the dealer from whom the instrument was purchased. It is likely that your Roberts' dealer will be able to attend to any defect quickly and efficiently but should it be necessary the dealer will return the instrument to the Company's service department for attention. In the event that it is not possible to return the instrument to the Roberts' dealer from whom it was purchased, please contact Roberts Radio Technical Services at the address shown on the rear of this manual.

These statements do not affect the statutory rights of a consumer.

ROBERTS RADIO TECHNICAL SERVICES

97-99 Worton Road

Isleworth Middlesex

TW7 6EG

Technical Helpline :- 020 8758 0338 (*Mon-Fri during office hours*)

Website: <http://www.robertsradio.co.uk>



© 2008 Roberts Radio Limited

Issue 1

