

ROBERTS

Sound for Generations

SC9911

3 Band Stereo Radio Cassette
Recorder

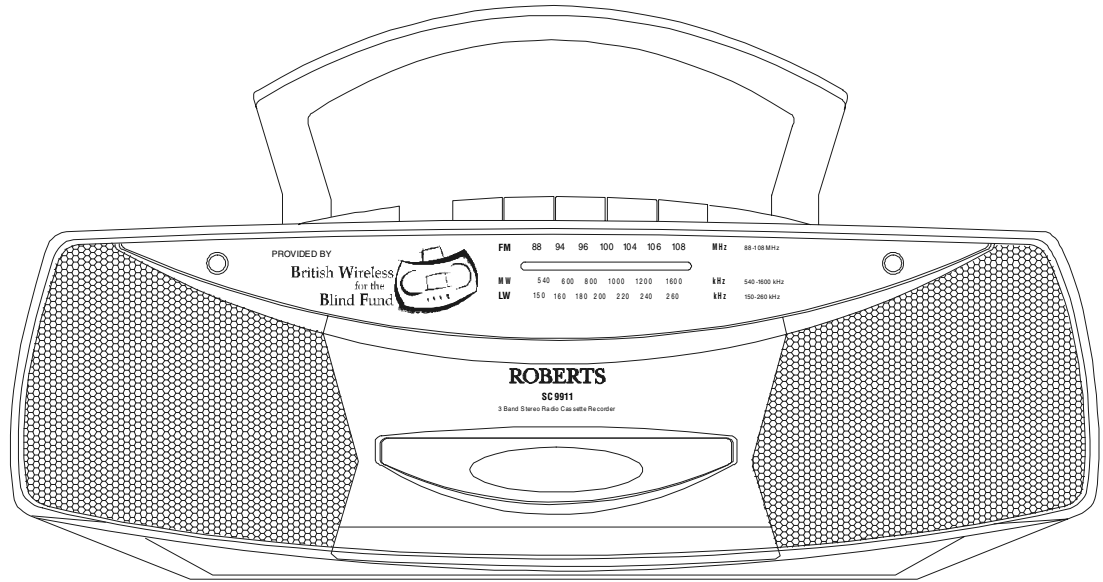

Please read this manual before use

Controls

(Top)

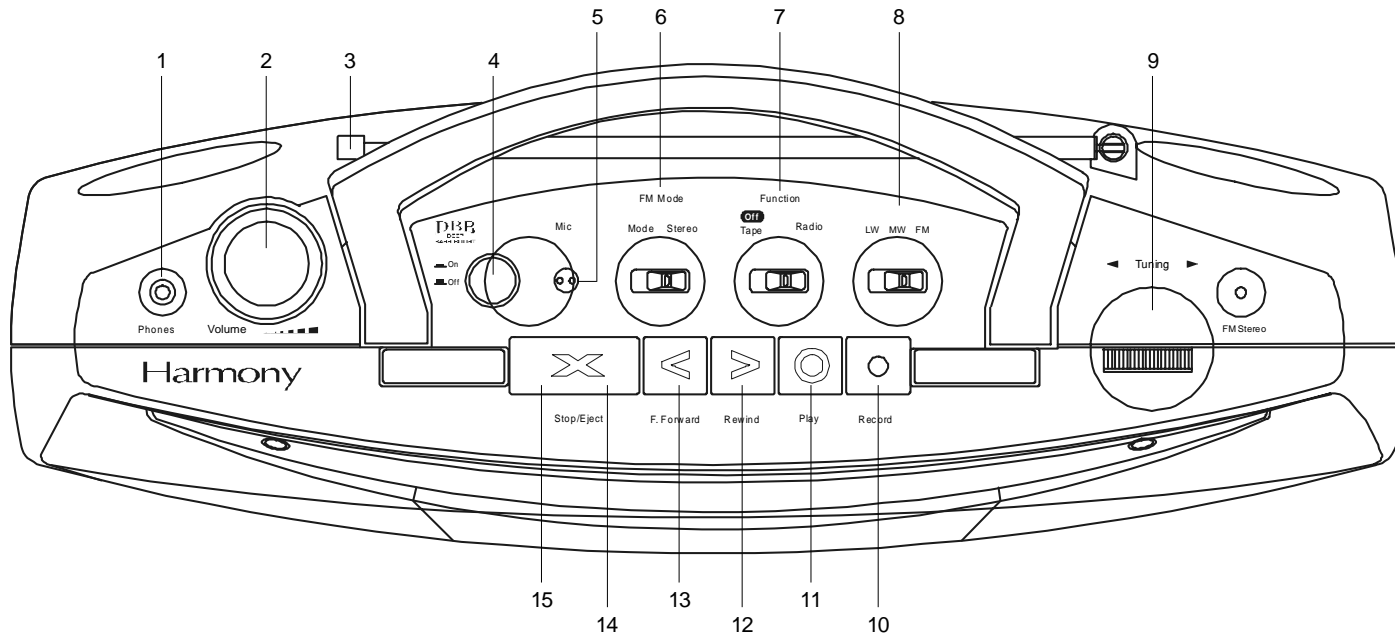

1. Headphone socket

2. Volume control

3. Telescopic aerial

4. Deep bass boost switch

5. Microphone

6. Mono/Stereo & beat cut switch

7. Function switch

8. Waveband switch

9. Tuning control

10. Record button

11. Play button

12. Rewind button

13. Fast forward button

14. Stop/eject button

15. Pause button

Controls

(Front)

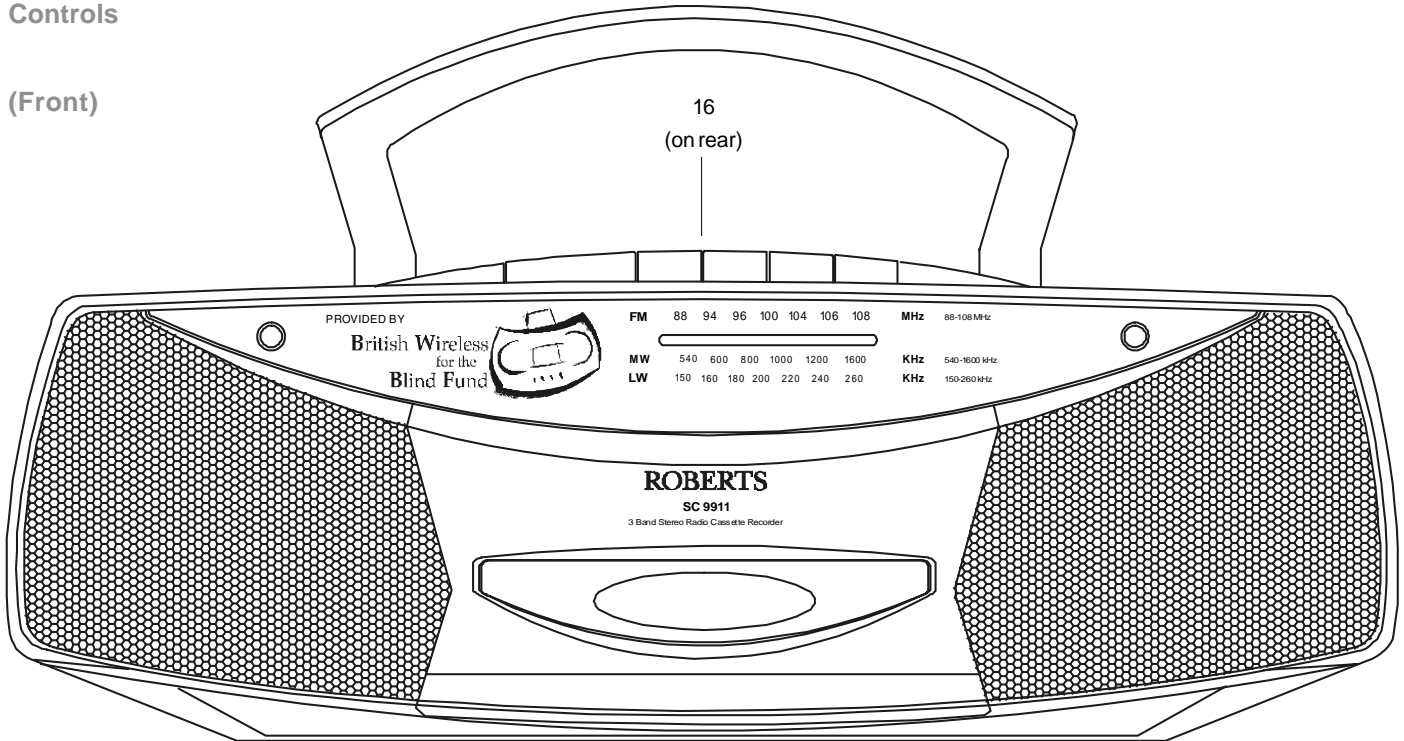

16. External mic socket (on rear)

Battery operation

1. Remove the **Battery cover** on the rear of the unit by pushing the catches in the direction of the arrow.
2. Insert four LR14 (C size) batteries into the remaining spaces in the battery compartment. Take care to ensure all batteries are inserted with the correct polarity as shown inside the battery compartment. Replace the battery cover.
3. Reduced power, distortion, and a 'stuttering' sound are all signs that the batteries may need replacing.
4. If your radio cassette is not to be used for any extended period of time it is recommended that the batteries are removed from the radio.

We would recommend for economy, that the SC9911 is used on the mains whenever possible with battery operation for occasional or stand-by use only.

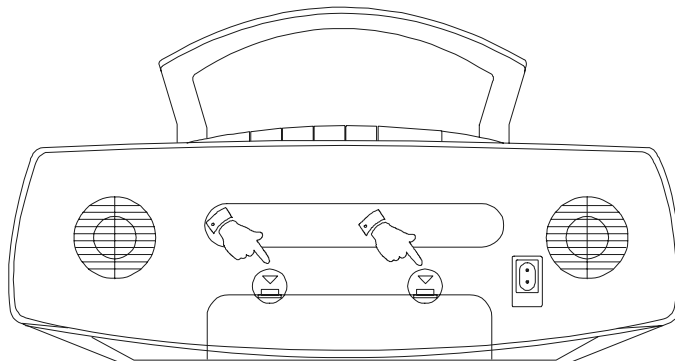

Mains operation

1. Place your radio cassette on a flat surface.
2. Plug the mains lead into the **Mains socket** located on the rear of your radio cassette ensuring that the plug is pushed fully into the socket.
3. Plug the other end into a wall socket and switch on. The batteries will be automatically disconnected.

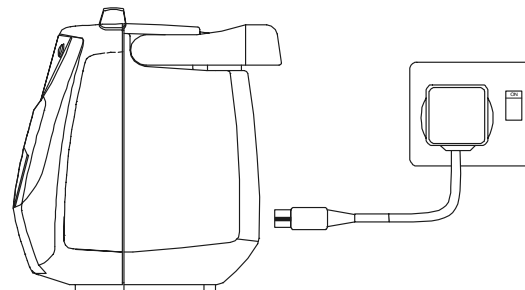

Listening to the radio

FM operation

1. Set the **Function switch** to the 'Radio' position.
2. Select 'FM' using the **Waveband switch**.
3. Adjust the **Volume control** until a hissing sound is heard.
4. The **Telescopic aerial** which is only operational on FM, should be fully extended.
5. Carefully tune to the desired station using the **Tuning control**.
6. Angle and rotate the **Telescopic aerial** to a position giving the best reception. A knuckle joint at the base of the aerial allows this movement and an angle of 45 degrees will usually be satisfactory. The FM band is marked in Megahertz (MHz).
7. To receive stereo broadcasts set the **Mono/Stereo** to the 'Stereo' position the **Stereo indicator** will light up. If the station being received is weak some hiss may be audible, to reduce the hiss set the **Mono/Stereo** switch to the 'Mono' position to return to mono operation.
8. Adjust the **Deep bass boost** switch to the required position.
10. To switch off the radio set the **Function switch** to the 'Tape Off' position.

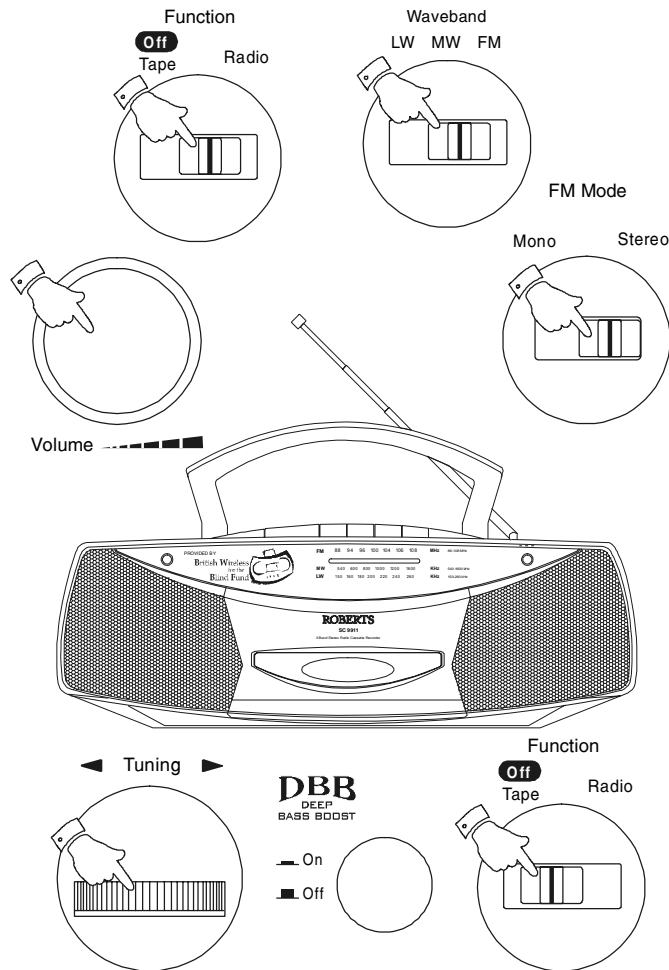

If you need any further advice, please call our Technical Helpline on :-
020 8758 0338 (Mon-Fri)

Medium and long wave operation

1. Set the **Function switch** to the 'Radio' position.
2. Select 'MW' or 'LW' using the **Waveband switch**.
3. Adjust the **Volume control** until a hissing sound is heard.
4. Carefully tune to the desired station using the **Tuning control**.
5. Rotate your radio cassette for optimum reception.
6. The MW and LW bands are marked in kilohertz (kHz).
7. Adjust the **Deep bass boost** switch to the required position.
8. To switch off the radio set the **Function switch** to the 'Tape Off' position.

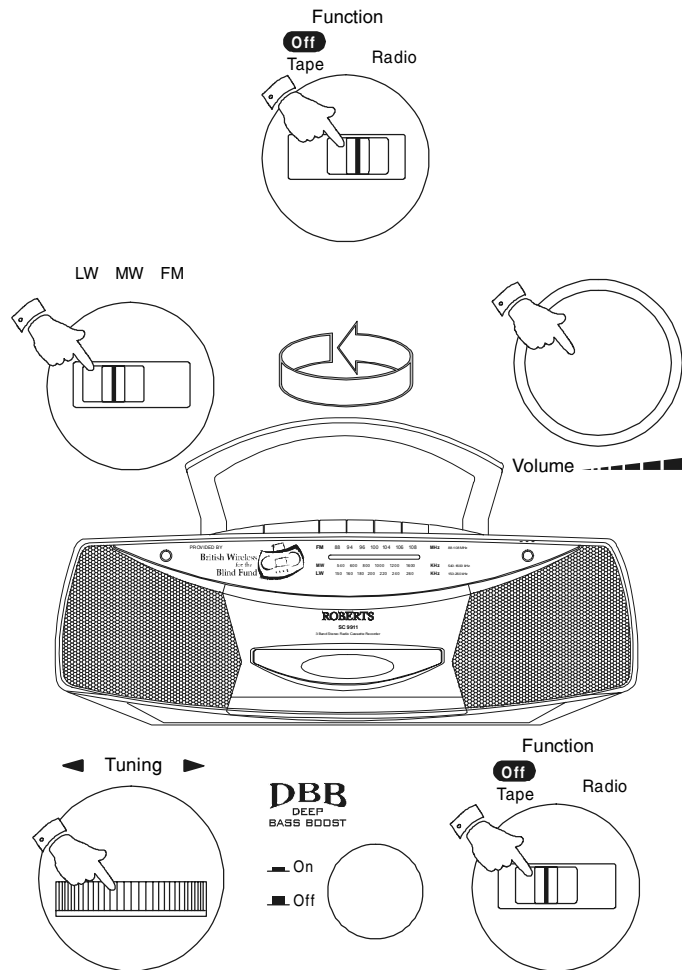

Listening to cassette tapes

1. Set the **Function switch** to the 'Tape' position.
2. Press the **Stop eject button** to open the **Cassette compartment**.
3. Insert a pre-recorded cassette with the tape surface uppermost and the side with the desired recording towards you.
4. Close the **Cassette compartment**.
5. Depress the **Play button** and adjust the **Volume control** to suit your personal taste.
6. Adjust the **Deep bass boost** switch to the required position.
7. Use the **Fast forward** or **Rewind buttons** to locate a specific part of the tape.
8. To stop the tape and switch off your radio cassette press the **Stop/Eject button**.

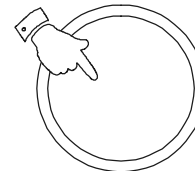
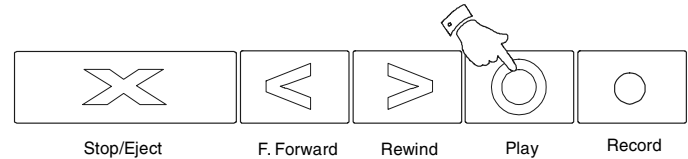
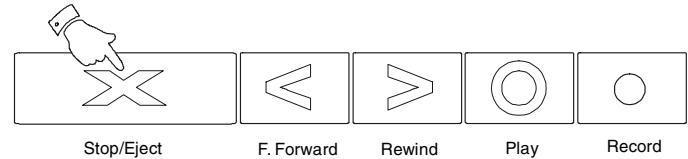
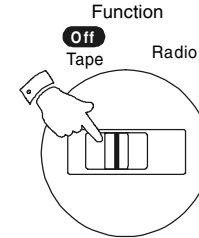

Volume

DBB
DEEP
BASS BOOST

On

Off

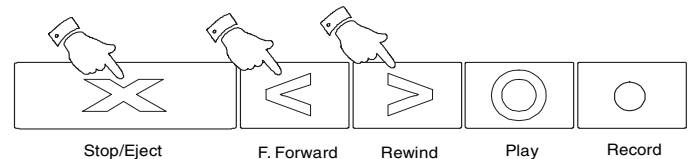
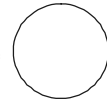

If you need any further advice, please call our Technical Helpline on :-
020 8758 0338 (Mon-Fri)

Recording from the Radio

1. Set the **Function switch** to the 'Radio' position.
2. Tune in to the desired station.
3. Adjust the **Volume control** to suit your requirements.
4. Insert a blank cassette with the tape surface uppermost.
5. Depress the **Record button** to commence recording.
6. The recording level is set automatically and is not affected by the setting of the **Volume control**.
7. To stop the recording press the **Stop/Eject button**.
8. When recording from the MW or LW bands a whistle may occur. To remove the whistle slide the **Mono/Stereo & beat cut switch** to the position giving best reception..

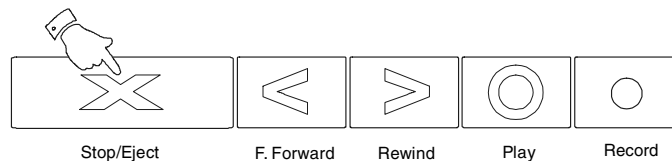
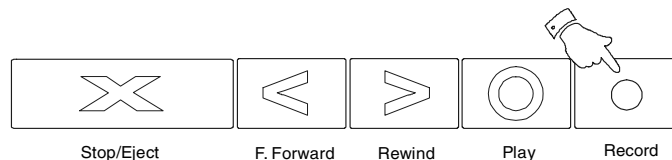
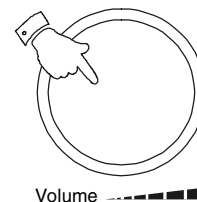
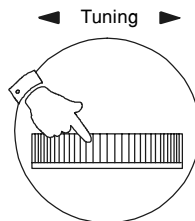
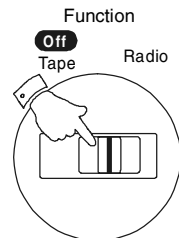

Recording from the Internal Microphone

1. Set the **Function switch** to the 'Tape' position.
2. Insert a blank cassette with the tape surface uppermost.
3. Press the **Record button** to commence recording.

*Note : to reduce background noise it is important to speak as close as possible to the **Internal microphone** .*

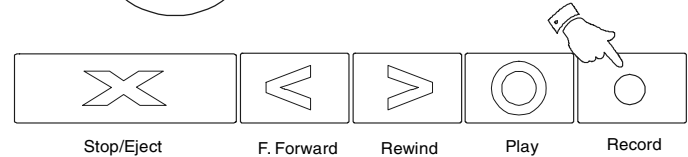
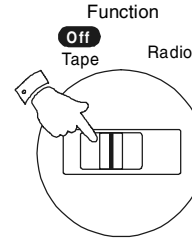

Recording using an External Microphone

A 3.5mm socket (25) located on the rear of your radio cassette is provided for use with external microphones. Inserting a plug into this socket will automatically mute the internal microphone.

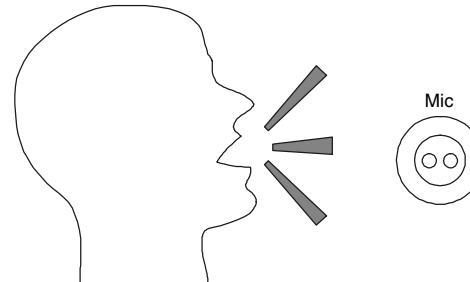

Headphones socket

A 3.5mm **Headphone Socket** located on the top of your radio cassette is provided for use with either headphones or an earpiece. Inserting a plug into the socket automatically mutes the internal loudspeaker.



Preventing accidental erasure

To safeguard your recordings against accidental erasure, break off the appropriate tab on the cassette as shown. There is one tab for each side of the cassette. This will prevent the Record button from being pressed. To restore the cassette to normal, seal the tab openings with a small piece of self-adhesive tape.

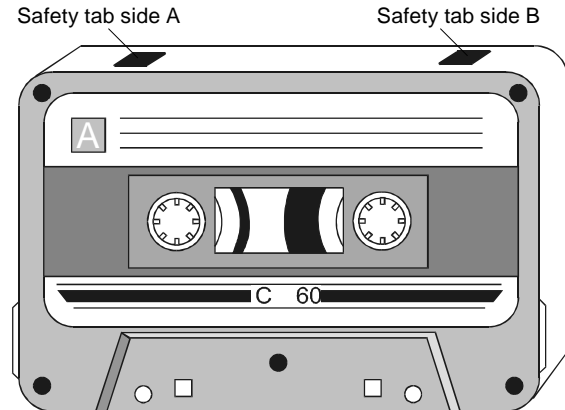

Cleaning the Heads

The binder and oxide from magnetic tapes can accumulate on the pinch roller (A) the capstan shaft (B) and also the heads (C and D). This will impair the sound quality.

To clean these parts proceed as follows:-

1. Turn off the power to the unit.
2. Press the Stop/Eject button (3).
3. Press the Play button (6) and the heads will be clearly seen.
4. Clean the surfaces (A, B, C, D) with a lint free rag or cotton swab soaked in alcohol. Press the stop/eject button as soon as cleaning is over.

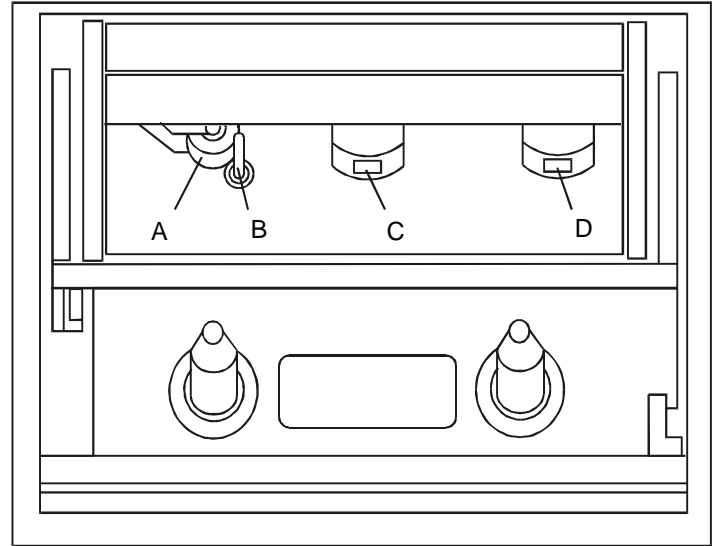

General

Do not allow this unit to be exposed to water or steam. It is recommended that the FM band be used wherever possible as better results in terms of quality and freedom from interference will usually be obtained than on the MW or LW bands.

Mains supply

The SC9911 will operate from a supply of AC 230 volts, 50Hz only.

DO NOT cut off the mains plug from this equipment. If the plug fitted is not suitable for the power points in your home or the cable is too short to reach a power point, then obtain an appropriate safety approved extension lead or adaptor. If in doubt consult your dealer.

If nonetheless the mains plug is cut off, remove the fuse and dispose of the plug immediately, to avoid a possible shock hazard by inadvertent connection to the mains supply.

If this product is not supplied with a mains plug, or one has to be fitted, then follow the instructions given below:

IMPORTANT. DO NOT make any connection to the larger terminal which is marked with the letter E or by the safety earth symbol \perp or coloured Green or Green-and-yellow.

The wires in the mains lead are coloured in accordance with the following codes :-

BLUE - NEUTRAL

BROWN - LIVE

The wire coloured BLUE must be connected to the terminal marked N or coloured BLACK.

The wire coloured BROWN must be connected to the terminal marked L or coloured RED.

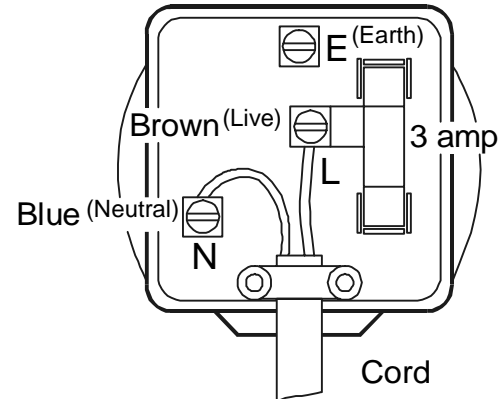

Fuse

When replacing the fuse only a 3A ASTA approved to BS1362 type should be used and be sure to re-fit the fuse cover.

IF IN DOUBT - CONSULT A QUALIFIED ELECTRICIAN.

Replacement fuse holders are available from Roberts Radio Technical Services Department at the address shown on the rear of this manual.

Specifications

Power Requirements

Mains: AC 230 volts, 50Hz  only
Batteries: Radio/Cassette 4 x LR14 (C size)

Frequency Coverage

FM 87.5 - 108MHz
MW 525 - 1610kHz
LW 150 - 260kHz

Circuit Features

Loudspeakers 2 x 75mm diameter
Output power 2 x 700mW
Aerial System FM Wire Aerial
MW Built-in Ferrite aerial
LW Built-in Ferrite aerial

ROBERTS RADIO LIMITED

PO BOX 130
MEXBOROUGH
SOUTH YORKSHIRE
S64 8YT

The Company reserves the right to amend the specification without notice.

Guarantee

This instrument is guaranteed for twelve months from the date of delivery to the original owner against failure due to faulty workmanship or component breakdown, subject to the procedure stated below. Should any component or part fail during this guarantee period it will be repaired or replaced free of charge.

The guarantee does not cover:

1. Damage resulting from incorrect use.
2. Consequential damage.
3. Receivers with removed or defaced serial numbers.

Procedure:

Any claim under this guarantee should be made through the dealer from whom the instrument was purchased. It is likely that your Roberts' dealer will be able to attend to any defect quickly and efficiently, but should it be necessary the dealer will return the instrument to the company's service department for attention. In the event that it is not possible to return the instrument to the Roberts' dealer from whom it was purchased, please contact Roberts Radio Technical Services department at the address shown on the rear of this manual before taking further action.

These statements do not affect the statutory rights of a consumer.

Notes

*If you need any further advice, please call our Technical Helpline on :-
020 8758 0338 (Mon-Fri)*

ROBERTS RADIO TECHNICAL SERVICES DEPARTMENT

97-99 Worton Road
Isleworth Middlesex
TW7 6EG

Technical Helpline:- 020 8758 0338 *(Mon-Fri)*

Issue 1

