

ROBERTS

R9927

3 Band Mains Battery
Portable Radio



Please read this manual before use

Contents

<i>Contents</i>	1
<i>Controls</i>	2-3
<i>Battery Operation</i>	4
<i>Mains Operation</i>	4
<i>Operating your radio - FM</i>	5
<i>Operating your radio - Medium and Long wave</i>	6
<i>Headphones</i>	7
<i>General</i>	7
<i>Specifications</i>	8
<i>Mains supply</i>	9
<i>Guarantee</i>	10

Controls

(Top)

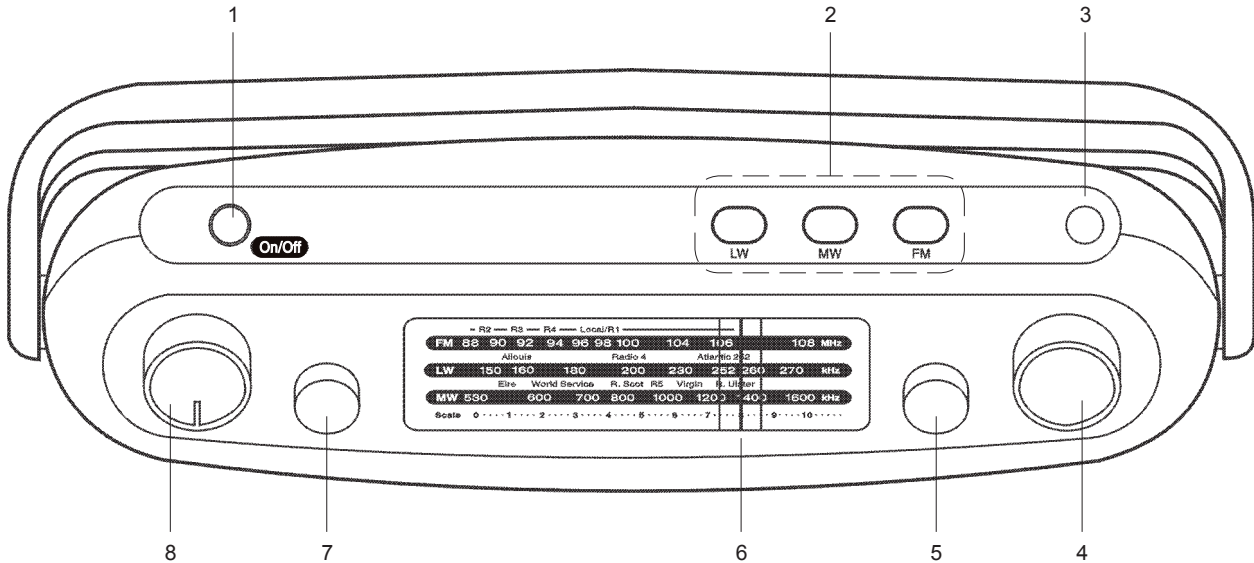

1. On/Off button
2. Waveband buttons
3. Telescopic aerial
4. Tuning control

5. Treble control
6. Dial pointer
7. Bass control
8. Volume control

Controls

(Rear)

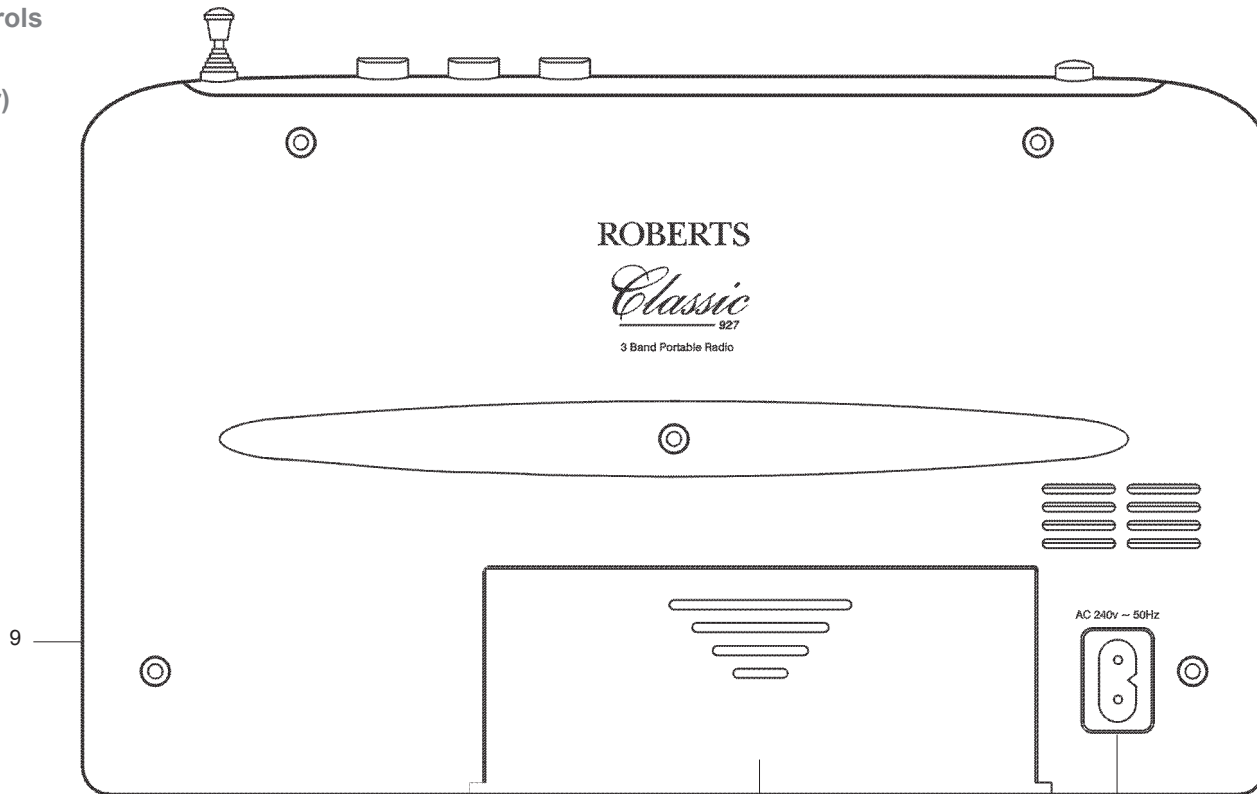

9. Headphone socket (on side)

10. Battery compartment

11. Mains socket

Battery operation

1. Remove the **Battery cover** on the rear of the unit by pushing the battery door in and downwards.
2. Insert four LR14 (C size) batteries into the spaces in the compartment. Take care to ensure all batteries are inserted with the correct polarity as shown inside the battery compartment. Replace the battery cover.
3. Reduced power, distortion and a 'stuttering' sound are all signs that the batteries may need replacing.
4. If the radio is not to be used for any extended period of time it is recommended that the batteries are removed from the radio.

We would recommend for economy that the R9927 is used on the mains whenever possible with battery operation for occasional or stand-by use only.

IMPORTANT: *The batteries should not be exposed to excessive heat such as sunshine, fire or the like. After use, disposable batteries should if possible be taken to a suitable recycling centre. On no account should batteries be disposed of by incineration.*

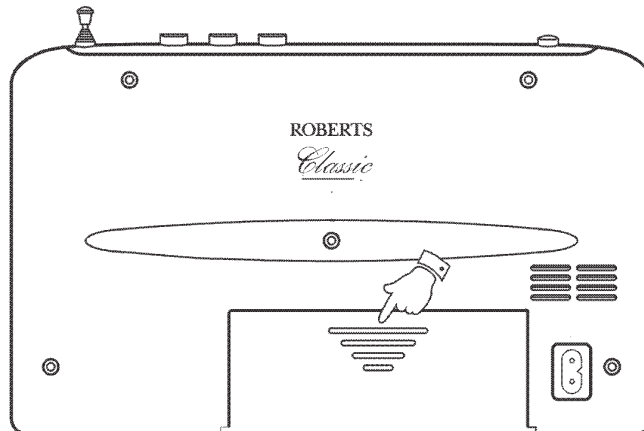

Mains operation

1. Place your radio on a flat surface.
2. Plug the mains lead into the **Mains socket** located on the rear of your radio ensuring that the plug is pushed fully into the socket.
3. Plug the other end of the mains lead into a wall socket and switch on the wall socket.

IMPORTANT: The mains plug is used as the means of connecting the radio to the mains supply. The mains socket used for the radio must remain accessible during normal use. In order to disconnect the radio from the mains completely, the mains plug should be removed from the mains socket outlet completely.

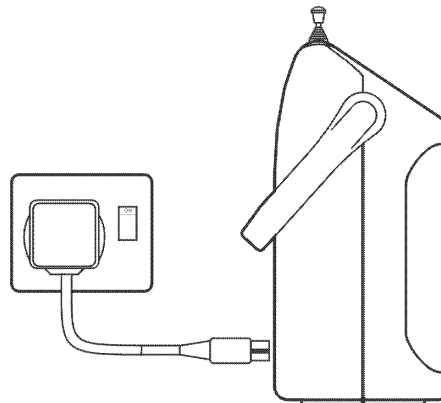

Operating your radio FM

1. Switch on your radio by pressing the **On/Off button**.
2. Press the **FM button** to select the FM waveband.
3. Adjust the **Volume control** until a hissing sound is heard.
4. Rotate the **Tuning control** to select the desired station. On FM the **Tuning scale** is marked in Megahertz (MHz).
5. For FM reception fully extend the **Telescopic aerial** and then angle and rotate for best reception
6. Adjust the **Volume** to the required setting.
7. Adjust the **Bass and Treble controls** to the required settings.
8. To switch off your radio press the **On/Off button**.

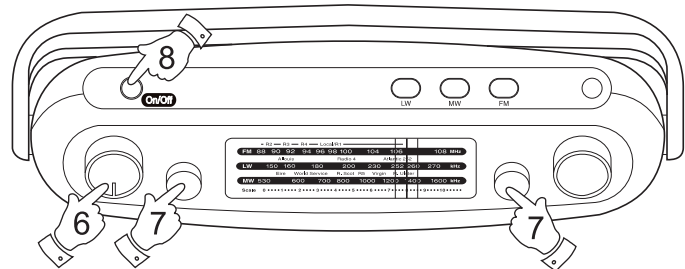
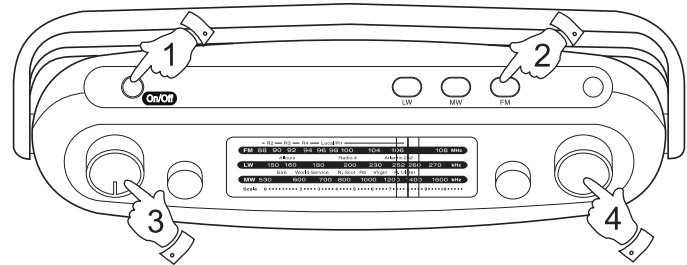

Operating your radio (Medium and Long wave)

1. Switch on your radio by pressing the **On/Off button**.
2. Press either the **MW** or **LW** button.
3. Adjust the **Volume control** until a hissing sound is heard.
4. Rotate the **Tuning control** to select the desired station. On MW and LW the **Tuning scale** is marked in kilohertz (kHz).
5. For MW or LW reception rotate your radio to the position giving best reception.
6. Adjust the **Volume** to the required setting.
7. Adjust the **Bass and Treble controls** to the required settings. Rotating the controls clockwise increases the bass or treble.
8. To switch off your radio press the **On/Off button**.

Note : The telescopic aerial is inoperative on MW and LW.

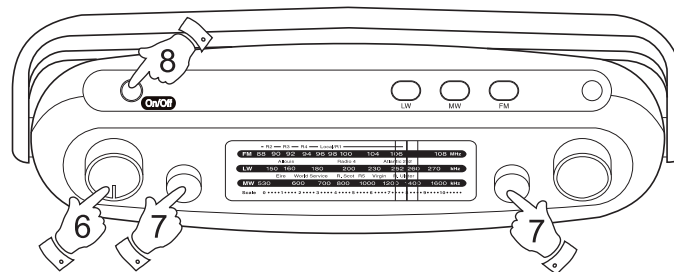
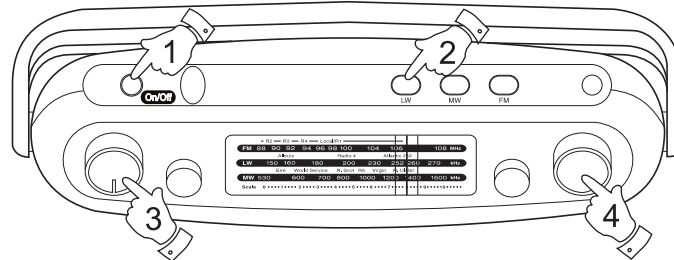

Trouble shooting

In case of malfunction due to electrostatic discharge, it may be necessary to reset the product to resume normal operation. This may generally be performed by turning the unit off and on. In some cases a more complete reset may be needed, either by removing all sources of power (battery and mains) when turned off.

Headphones

1. A **Headphone Socket** (3.5mm) located on the right hand end of your radio is provided for use with either headphones or an earpiece. Inserting the headphone plug automatically mutes the internal loudspeaker.

Please be aware that the sensitivity of headphones can vary widely. We therefore recommend setting the volume to a low level before connecting headphones to the radio.

IMPORTANT: Excessive sound pressure from earphones and headphones can cause hearing loss.



To prevent possible hearing damage, do not listen at high volume levels for long periods.

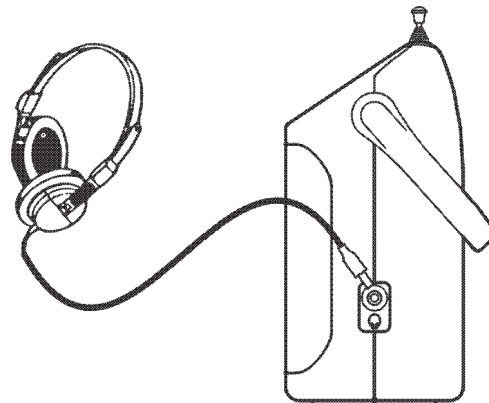

General

Do not allow this unit to be exposed to dripping or splashing. Do not leave your radio where excessive heat could cause damage such as in a parked car where the heat from the sun can build up even though the outside temperature may not seem too high. It is recommended that the FM band be used where ever possible as better results in terms of quality and freedom from interference will usually be obtained than on the MW or LW bands.

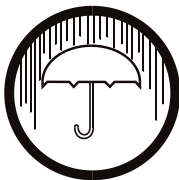

- No objects filled with liquids such as vases, shall be placed on the radio.
- It is recommended to operate the product such that there is a minimum distance (10cm recommended) to adjacent objects in order to ensure good ventilation.
- The ventilation of the product should not be restricted by covering it or its ventilation openings with items such as newspapers, table-cloths, curtains etc.
- No naked flame sources such as lighted candles should be placed on the product.
- It is recommended to avoid using or storing the product at extremes of temperature. Avoid leaving the unit in cars, on window sills in direct sunlight etc.
- The name plate is located on the bottom panel.
- The product must be used in a moderate climate.

Specifications

Power Requirements

Mains AC 230 volts, 50Hz  only
Batteries 4 x LR14 (C size)

Battery Life

Approx. 80hrs of listening for 4 hours a day at normal volume using alkaline cells.

Frequency Coverage

FM	87.5-108MHz
MW	522- 1620kHz
LW	144- 281kHz

Circuit Features

Loudspeaker	92mm 4ohms
Output Power	1W into 4ohms

Headphone socket 3.5mm dia

Aerial System	FM	Telescopic aerial
	MW	Built-in Ferrite aerial
	LW	Built-in Ferrite aerial

The Company reserves the right to amend the specification without notice.

Mains supply

The R9927 will operate from a supply of AC 230 volts, 50Hz ~ only.

DO NOT cut off the mains plug from this equipment. If the plug fitted is not suitable for the power points in your home or the cable is too short to reach a power point, then obtain an appropriate safety approved extension lead or adaptor. If in doubt consult your dealer.

If nonetheless the mains plug is cut off, remove the fuse and dispose of the plug immediately to avoid a possible shock hazard by inadvertent connection to the mains supply.

If this product is not supplied with a mains plug, or one has to be fitted, then follow the instructions given below:

IMPORTANT. DO NOT make any connection to the larger terminal which is marked with the letter E or by the safety earth symbol \perp or coloured Green or Green-and-Yellow.

The wires in the mains lead are coloured in accordance with the following codes :-

BLUE - NEUTRAL

BROWN - LIVE

The wire coloured BLUE must be connected to the terminal marked N or coloured BLACK.

The wire coloured BROWN must be connected to the terminal marked L or coloured RED.

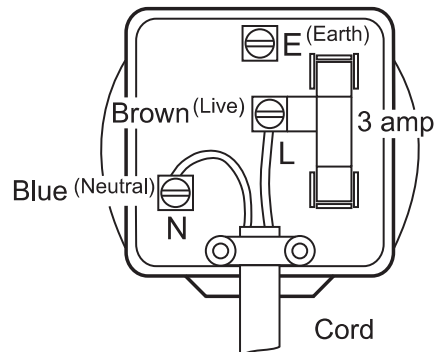

Fuse

When replacing the fuse only a 3A ASTA approved to BS1362 type should be used and be sure to re-fit the fuse cover.

IF IN DOUBT - CONSULT A QUALIFIED ELECTRICIAN.

Guarantee

This product is guaranteed for twenty four months from the date of purchase by the original owner against failure due to faulty workmanship or component breakdown, subject to the procedure stated below. Should any component or part fail during this guarantee period it will be repaired or replaced free of charge.

The guarantee does not cover:

1. Damage resulting from incorrect use.
2. Consequential damage.
3. Product with removed or defaced serial numbers.

N.B. Damaged or broken telescopic aerials will not be replaced under guarantee.

Procedure:

Any claim under this guarantee should be made through the dealer from whom the product was purchased. It is likely that your Roberts dealer will be able to attend to any defect quickly and efficiently, but should it be necessary the dealer will return the product to the company's service department for attention. In the event that it is not possible to return the product to the Roberts dealer from whom it was purchased, please contact Roberts Radio using the contact details on the www.robertsradio.com website.

For product repairs falling outside the guarantee period, please refer to the "Customer care" tab on the www.robertsradio.com website.

These statements do not affect the statutory rights of a consumer.



Issue 4

ROBERTS RADIO LIMITED

PO Box 130
Mexborough
South Yorkshire
S64 8YT

Website: <http://www.robertsradio.com>

© 2016 Roberts Radio Limited

