

**ROBERTS**  
Sound for Generations

**C9950**

Dual Speed Programmable  
Cassette Recorder



Please read this manual before use

## Contents

<i>Controls</i> .....	2	<i>Preventing accidental erasure</i> .....	20
<i>Timer display</i> .....	4	<i>General</i> .....	21
<i>Battery operation &amp; installation</i> .....	5	<i>Specifications</i> .....	21
<i>Carrying handle</i> .....	5	<i>Guarantee</i> .....	22
<i>Cassette tapes</i> .....	6		
<i>Using the AC adaptor</i> .....	6		
<i>Using headphones</i> .....	6		
<i>Setting the clock and day of the week</i> .....	7		
<i>Tape speed</i> .....	8		
<i>Listening to cassette tapes</i> .....	8		
<i>Recording from the radio</i> .....	9		
<i>Recording from the internal microphone</i> .....	10		
<i>Recording from the line in socket</i> .....	11		
<i>Recording from an external microphone</i> .....	12		
<i>Timed recordings</i> .....	13		
<i>Voice activated recordings</i> .....	15		
<i>Voice activated recording with timer</i> .....	16		
<i>Remote switch operation</i> .....	17		
<i>Recording a telephone call</i> .....	18		
<i>Line out socket</i> .....	19		
<i>Cassette tapes</i> .....	20		
<i>Cleaning the heads</i> .....	20		

# Controls

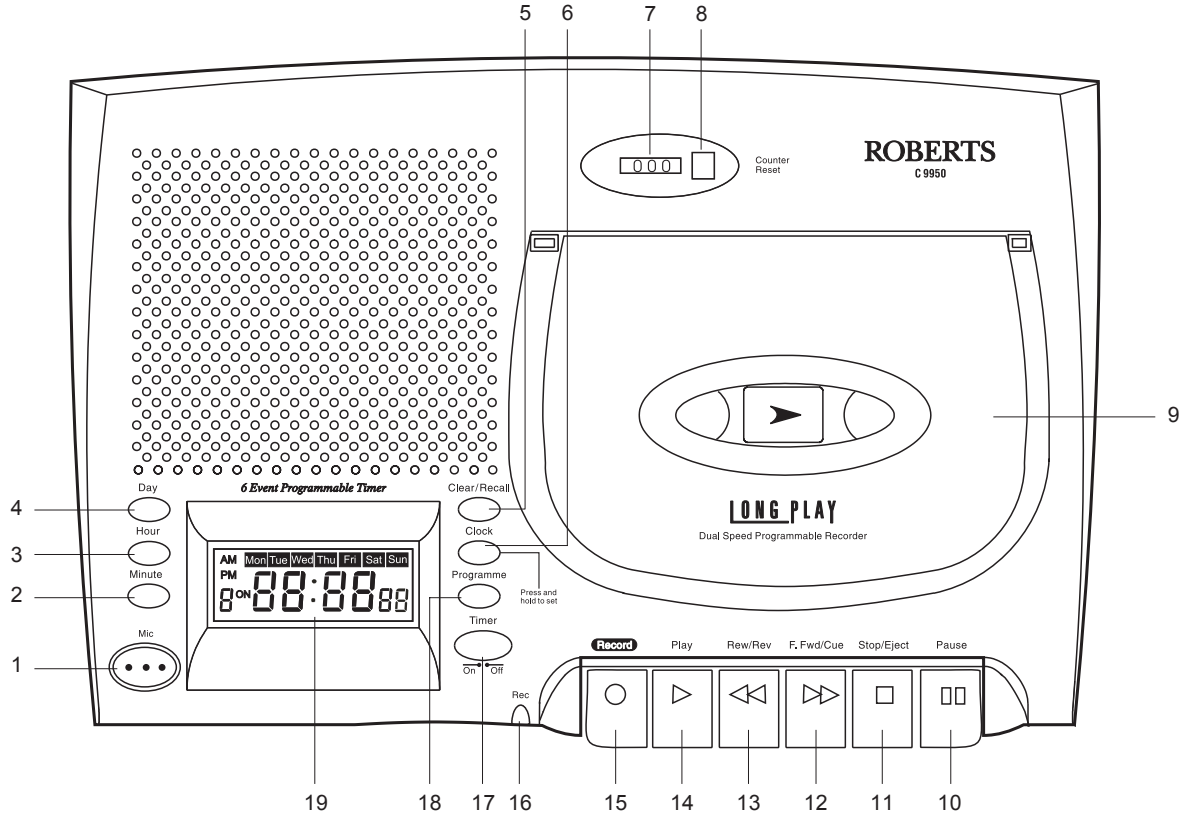

- |                        |                        |                       |                      |                         |
|------------------------|------------------------|-----------------------|----------------------|-------------------------|
| 1. Built-in microphone | 5. Clear/Recall button | 9. Cassette door      | 13. Rew/Rev button   | 17. Timer ON/OFF switch |
| 2. Minute button       | 6. Clock set button    | 10. Pause button      | 14. Play button      | 18. Program button      |
| 3. Hour button         | 7. Tape counter        | 11. Stop/Eject button | 15. Record button    | 19. Timer display       |
| 4. Day button          | 8. Tape counter reset  | 12. F.Fwd/Cue button  | 16. Record indicator |                         |

## Controls (cont.)

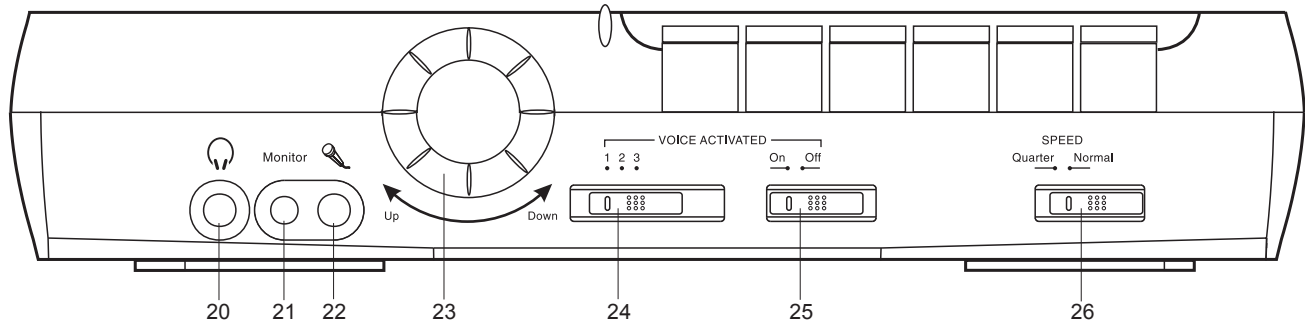

- 20. Headphone socket
- 21. Monitor socket
- 22. Microphone socket
- 23. Volume control

- 24. Voice sensitivity level
- 25. Voice activated switch
- 26. Speed switch

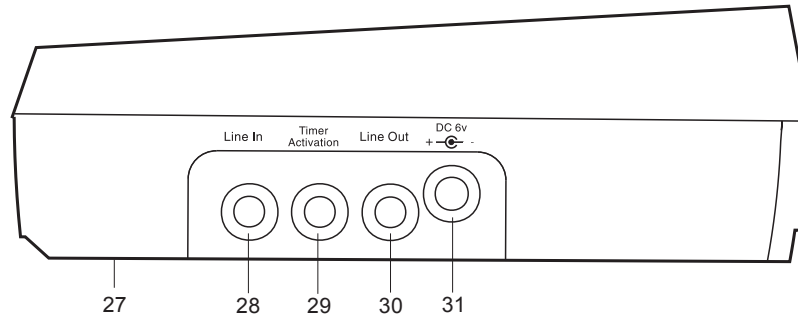

- 27. Beep switch (on underside)
- 28. Line in socket
- 29. Timer activator socket

- 30. Line out socket
- 31. DC power input socket

## Timer Display

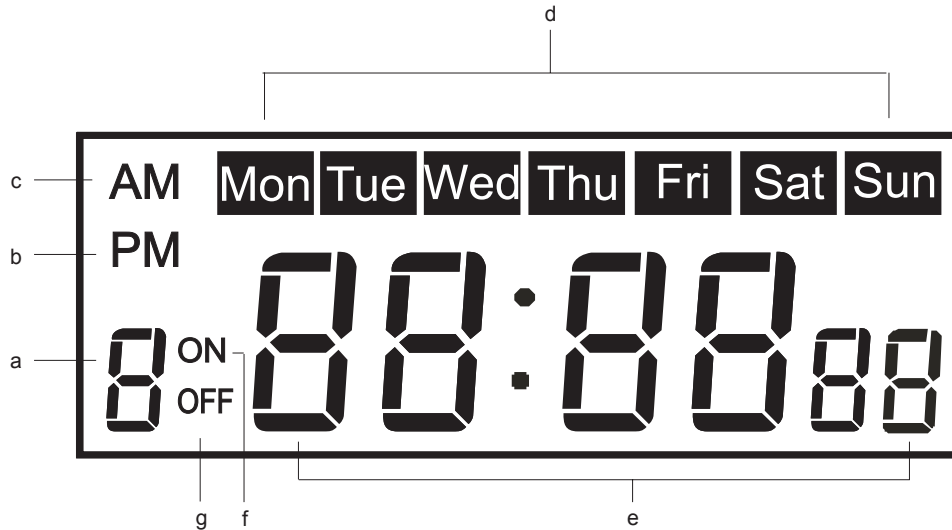

- a. Timer number
- b. PM indicator
- c. AM indicator

- d. Day of week indicator
- e. Hours minutes and seconds indicators
- f. On time indicator
- g. Off time indicator

## Battery operation & installation

1. Remove the **Battery cover** on the base of the unit by pushing the ribbed tab in the direction of the arrow.
2. Insert 4 x LR14 (C size) batteries into the battery compartment. Take care to ensure all batteries are inserted with the correct polarity as shown inside the battery compartment.
3. Replace the **Battery cover**.

**Batteries are necessary to maintain the clock and timer memories in the event of a mains power failure.**

Reduced power, distortion and a 'stuttering' sound are all signs that the batteries may need replacing.

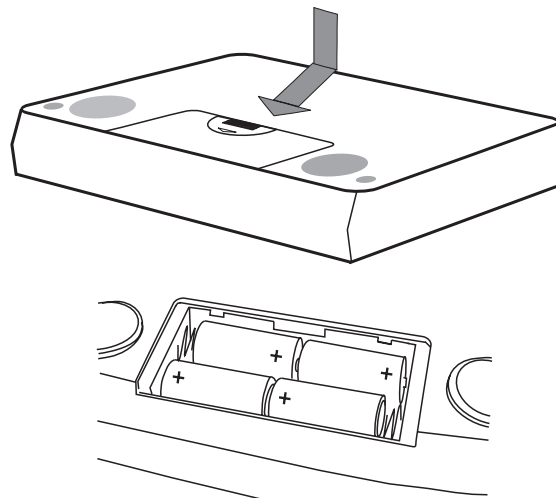

**We would recommend for economy that the C9950 is used on the mains whenever possible with battery operation for occasional or stand-by use only.**

---

## Carrying handle

Your cassette recorder has a handle for travel purposes. To access the handle place your fingers in the well underneath and to the right hand side of the recorder and pull gently.

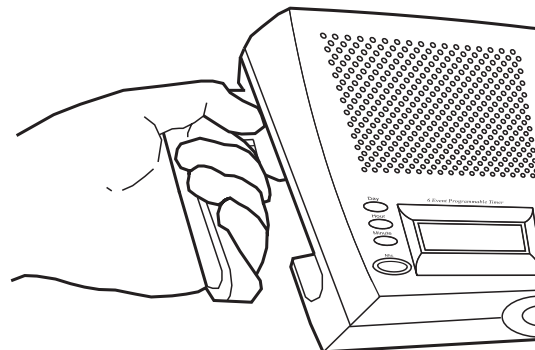

## Cassette Tapes

High quality 90 min (C90) tapes are recommended for use in your cassette recorder. In tests these provide a balance between maximum recording time and prolonged tape life. Audio cassette tapes are available up to 120 minutes in length, however the tape material is thin and may stretch or break during recording or playback and are not recommended for use with your cassette recorder.

## Using the AC adaptor

Insert the adaptor plug into the DC socket on the right side of your cassette recorder. Plug the adaptor into a standard 13A mains socket outlet. Whenever the adaptor is used the batteries are automatically disconnected.

The AC adaptor should be disconnected from the mains supply and your cassette recorder when not in use.

**We would recommend for economy that the C9950 be used via an AC adaptor whenever possible with battery operation for occasional or stand-by use only.**

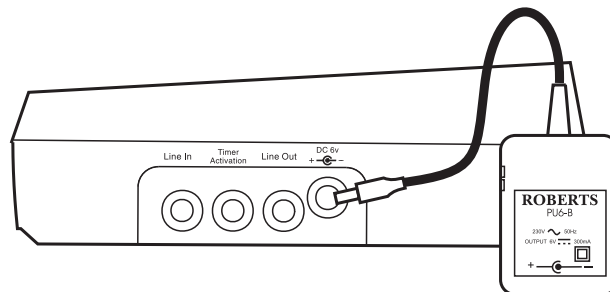

## Using headphones (not included)

Headphones or earphones for use with your C9950 should be stereo and fitted with a 3.5mm stereo jack plug. Insert the headphone plug into the

 socket located on the front left side of your cassette recorder. When the headphones are plugged in the loudspeaker is automatically disconnected.

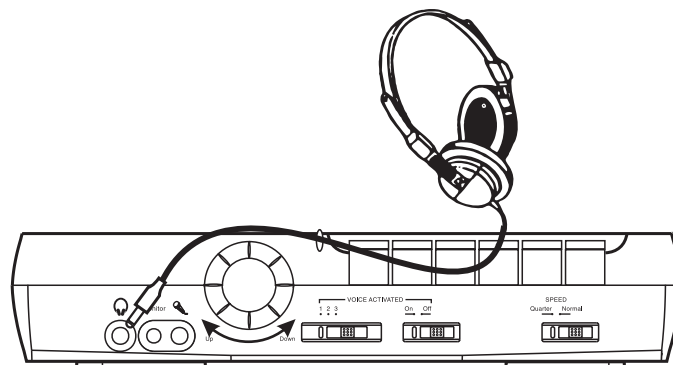

## Setting the clock and day of the week

1. To set the day of the week press and hold down the **Clock button**.
2. Whilst holding down the **Clock button** press the **Day button** to select the required day.
3. To set the time press and hold down the **Clock button**.
4. Whilst holding down the **Clock button** press the **Hour**, or **Minute buttons** to set the time. Release the buttons when the correct time is reached. The clock uses a 12 hour display with **AM/PM indicators**. Ensure that the correct 12 hour cycle is selected.

**Note:** each time you press the **Minute button** the seconds reset to '00'.

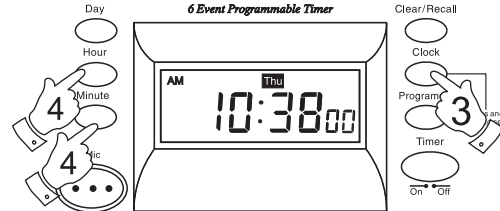
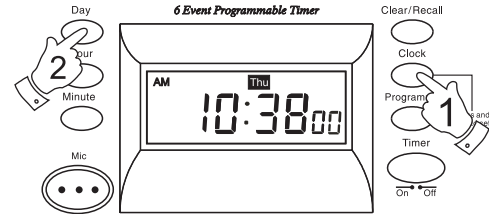



## Tape speed

Your cassette recorder has the ability to record and playback at both **Normal** and **Quarter** speed. **Quarter** speed gives 4 times longer recording time than **Normal** speed. **Normal** speed should be used for music or when higher quality is required. **Quarter** speed can be used for speech, plays or talk shows where the highest quality is not important.

## Listening to cassette tapes

1. Press the **Stop/Eject** button to open the cassette compartment.
2. Insert a cassette with the tape facing towards you and the side with the desired recording uppermost. Close the cassette compartment.
3. For normal pre-recorded tapes set the **Speed switch** to the Normal position.
4. Depress the **Play** button.
5. Adjust the **Volume control** to suit your personal taste.
6. Use the **Fast forward** or **Rewind** buttons to locate a specific part of the tape.
7. If you wish to temporarily stop the playback press the **Pause** button. When you are ready to resume playback press the **Pause** button a second time.

Note: Your cassette recorder will playback tapes in stereo via the Headphone socket or Line output socket.

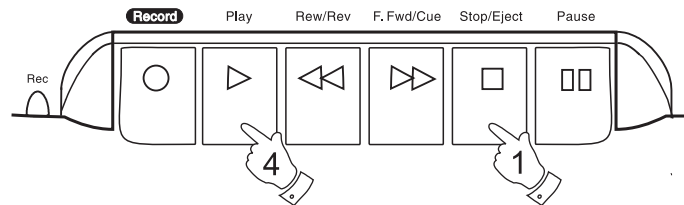

SPEED  
Quarter    Normal

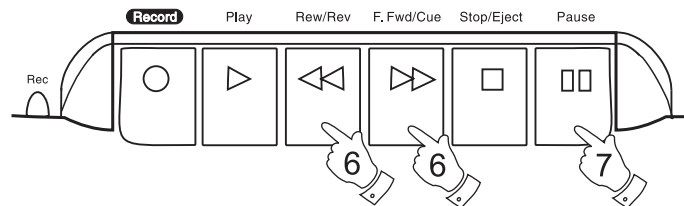
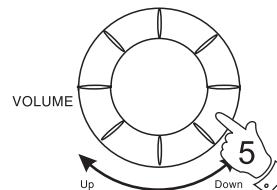
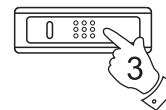

## Recording from a radio

Your cassette recorder can record from any radio that has a 3.5mm headphone or line out socket. Recording from other types of socket is possible using adaptors available from your local dealer.

1. Press the **Stop/Eject button** to open the cassette compartment. Insert a cassette with the tape facing towards you and the side on which you wish to record uppermost. Close the cassette compartment.
2. Ensure that the **Timer** and **Voice activated switches** are set to the 'Off' position.
3. Set the **Speed switch** to the required position. Reset the **Tape counter** if desired.
4. Switch on your radio and tune in to the station you wish to record. Adjust the volume to normal listening level.
6. Plug one end of the supplied **Red patch cord** into your radio line out or headphone socket and the other end into the **Line In socket** on your cassette recorder.
7. Press the **Record button** to commence recording, the **Recording indicator** will flash.
8. Adjust your cassette recorder's **Volume control** to suit your requirements. The recording level is set automatically and is not affected by the setting of the **Volume control**.
9. To stop the recording press the **Stop/Eject button**.

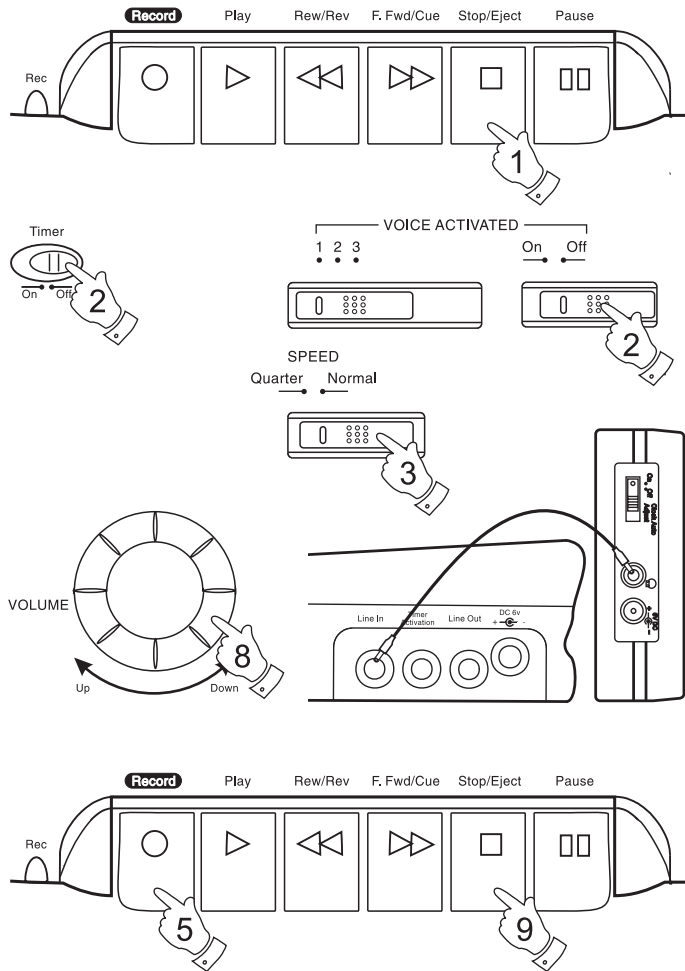

## Recording from the internal microphone

1. Press the **Stop/Eject button** to open the cassette compartment. Insert a cassette with the tape facing towards you and the side on which you wish to record uppermost. Close the cassette compartment.
2. Ensure that the **Timer** and **Voice activated switches** are set to the 'Off' position.
3. Set the **Speed switch** to the required position. Reset the **Tape counter** if desired.
4. Ensure that no leads are connected to the **Microphone or Line In sockets**.
5. Press the **Record button** to commence recording, the **Recording indicator** will flash.
6. The recording level is set automatically and is not affected by the setting of the **Volume control**.
7. To stop the recording press the **Stop/Eject button**.

**Note :** to reduce background noise it is important to speak as close as possible to the **Internal microphone** .

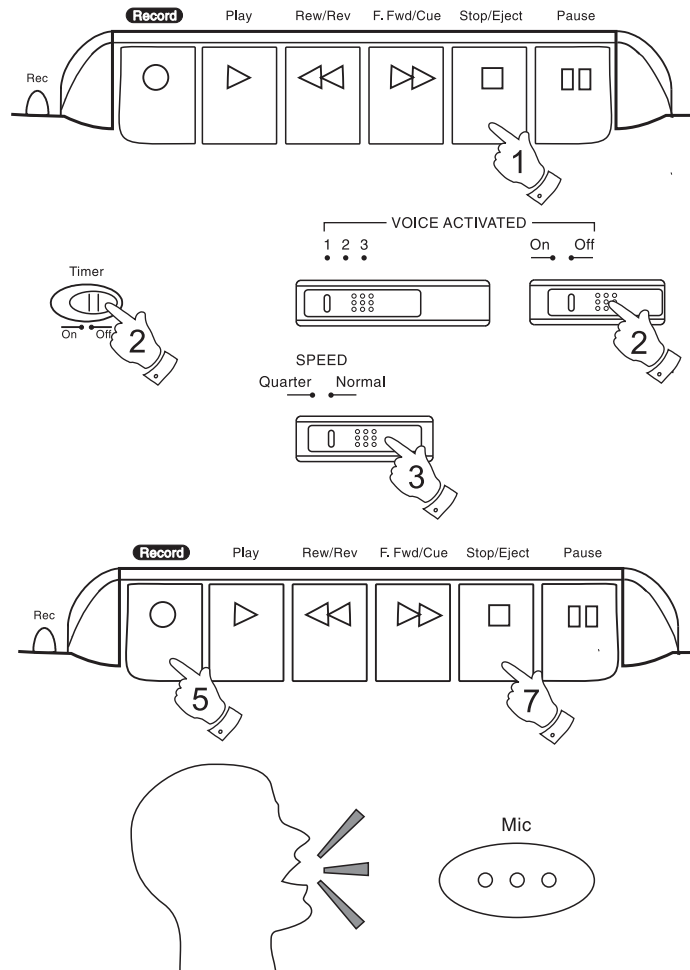

## Recording from the line in socket

Your cassette recorder can record from any other product that has a 3.5mm headphone or line out socket. Recording from other types of socket is possible using adaptors available from your local dealer.

1. Press the **Stop/Eject button** to open the cassette compartment. Insert a cassette with the tape facing towards you and the side on which you wish to record uppermost. Close the cassette compartment.
2. Ensure that the **Timer** and **Voice activated switches** are set to the 'Off' position.
3. Set the **Speed switch** to the required position. Reset the **Tape counter** if desired.
4. Plug one end of the supplied **Red patch cord** into the line out or headphone socket on the device you are recording from and the other end into the **Line In socket** on your cassette recorder.
5. Press the **Record button** to commence recording, the **Recording indicator** will flash.
6. The recording level is set automatically and is not affected by the setting of the **Volume control**.
7. To stop the recording press the **Stop/Eject button**.

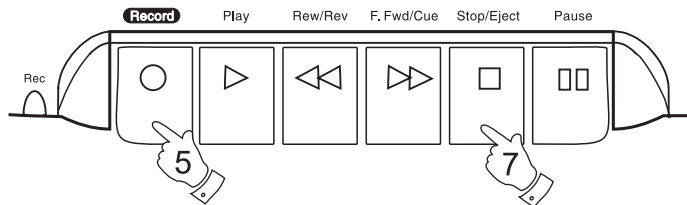
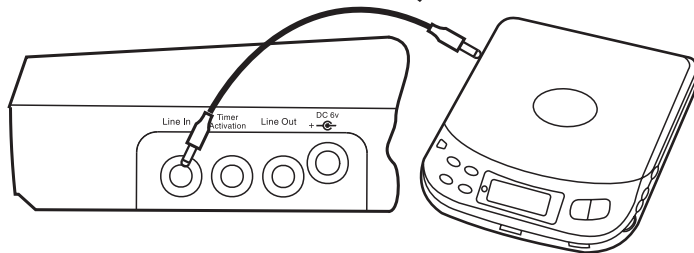
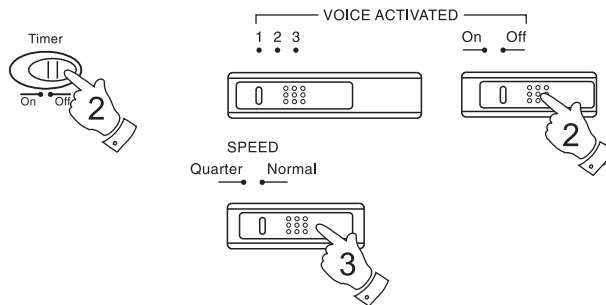
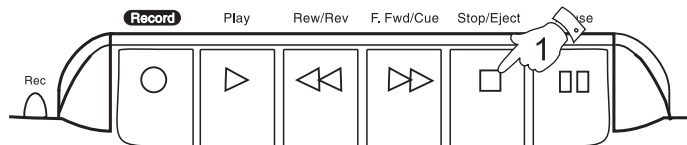

## Recording from an external microphone (not supplied)

Your cassette recorder can record from an external microphone. Most types of microphone fitted with a 3.5mm plug will work with your cassette recorder.

1. Press the **Stop/Eject button** to open the cassette compartment. Insert a cassette with the tape facing towards you and the side on which you wish to record uppermost. Close the cassette compartment.
2. Ensure that the **Timer** and **Voice activated switches** are set to the 'Off' position.
3. Set the **Speed switch** to the required position. Reset the **Tape counter** if desired.
4. Connect a microphone to the **Mic input socket** located on the front of your cassette recorder. Ensure that no connection has been made to the **Line In socket**.
5. Press the **Record button** to commence recording, the **Recording indicator** will flash.
6. The recording level is set automatically and is not affected by the setting of the **Volume control**.
7. To stop the recording press the **Stop/Eject button**.

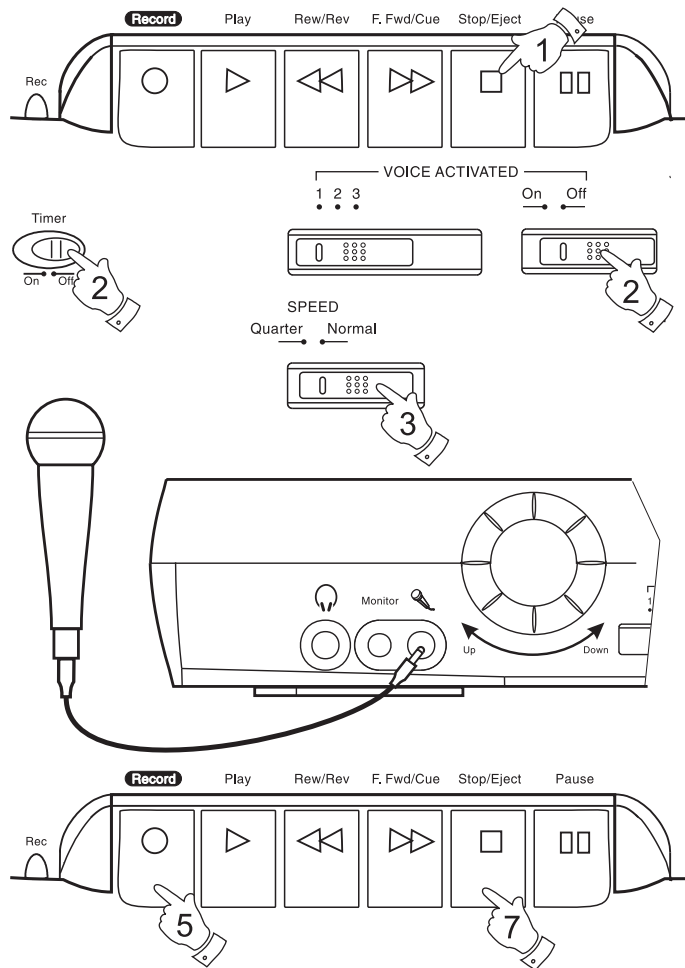

## Timed recordings

Your cassette recorder has a timer which allows six separate timed recordings to be made. Each timer can be set to record a particular day of the week, everyday of the week or Saturday/Sunday. If the timer is set to record everyday of the week at the same time this only uses up one of the six timed recordings. If another timer is set to record, say, on Saturday/Sunday then four other timers remain unused.

1. Insert a cassette with the tape facing towards you and the side on which you wish to record uppermost. Close the cassette compartment. Reset the **Tape counter** if desired.
2. Set the **Speed switch** to the required setting and ensure that the **Voice Activated Switch** is set to the "Off" position.
3. To set the start time, press the **Program** button once. The number '1' and 'ON' will appear in the display.
4. Press the **Day** button until the desired day or days of week appear in the display. Possible combinations are single day, everyday, every week day or weekends.
5. Select the hour at which you wish to record by pressing the **Hour** button until the desired hour appears in the display. The clock uses a 12 hour display with **AM/PM indicators**. Ensure that the correct 12 hour cycle is selected.
6. Select the minute you would like the recording to begin by pressing the **Minute** button until the desired minute appears in the display.

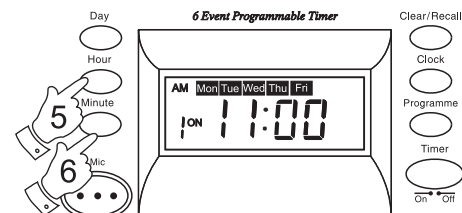
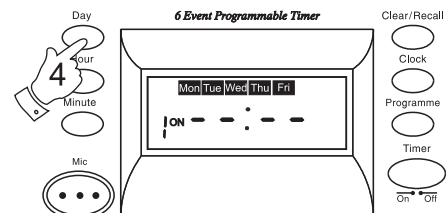
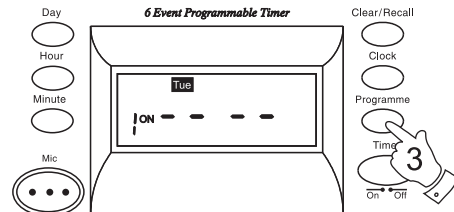
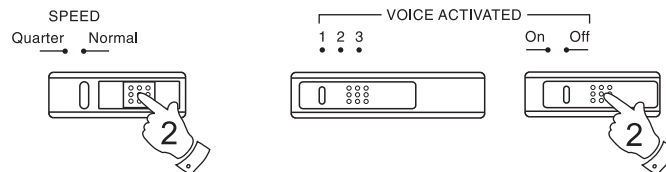

## Timed recordings (cont.)

7. To set the stop time, press the **Program button** once. The number '1' and 'OFF' will appear in the display.
8. Select the day on which you wish to stop recording by pressing the **Day** button until the desired day appears in the display.
9. Select the hour at which you wish to stop recording by pressing the **Hour** button until the desired hour appears in the display.
10. Select the minute at which you wish to stop recording by pressing the **Minute** button until the desired minute appears in the display.
11. After you have set the timer you can press the **Clock button** to return to normal time display.
12. Set the **Timer switch** to the "On" position. Press the **Record button**. Your cassette recorder will start and stop recording at the programmed times.
13. If you wish to program your cassette recorder to record another event, press the **Program button** until the number '2' and 'ON' appear in the display. Repeat above steps to program ON/OFF times.
14. Whilst an ON or OFF time is showing in the display the **Clear/Recall button** can be used to clear or recall a previously set ON/OFF time.

**Note:** Ensure correct day for Off time is set when recording across midnight e.g. if recording starts at Monday 11:45PM and finishes at 12:15AM Tuesday, Off day should be set to Tuesday.

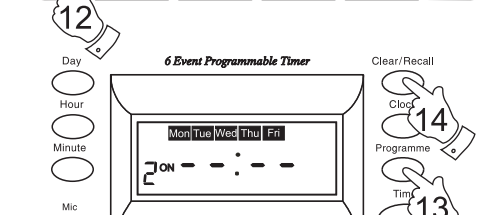
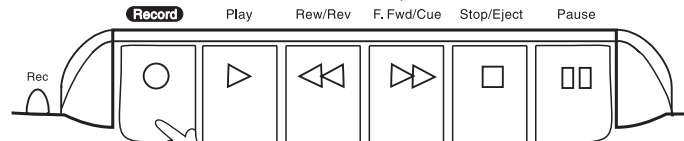
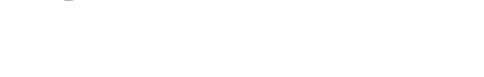
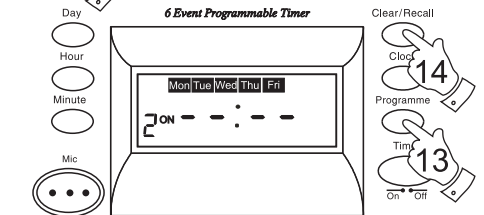
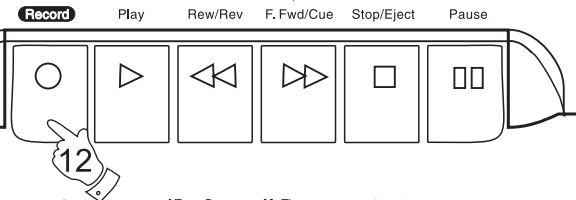
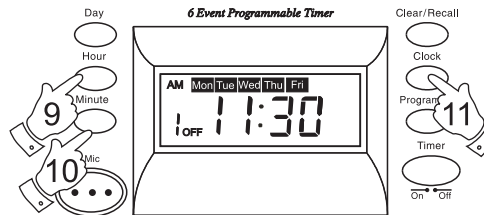
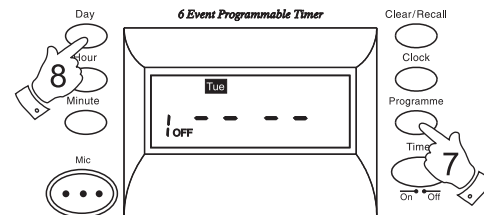

## Voice activated recordings

Your cassette recorder has the ability to make recordings which start and stop depending on the sound level present at the **Internal Microphone**, **Microphone socket** or **Line in sockets**. The sound level that will start and stop recordings can be set with the **Voice Sensitivity switch**.

Position "1" is the most sensitive position, "3" is the least sensitive. It will be necessary to experiment with the position of the **Voice Sensitivity switch** to achieve the desired result.

1. For highest quality recordings set the **Speed switch** to the "Normal" position. For maximum recording time set the **Speed switch** to the "Quarter" position.
2. Insert a cassette with the tape facing towards you and the side on which you wish to record uppermost. Close the cassette compartment. Reset the **Tape counter** if desired.
3. Set the **Voice Activated switch** to the 'On' position.
4. Press down the **Record button**.
5. The recording will commence when the sound level present at the **Internal Microphone**, **Microphone socket** or **Line in sockets** is of a sufficient level.

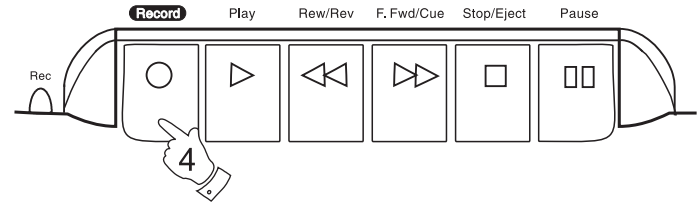
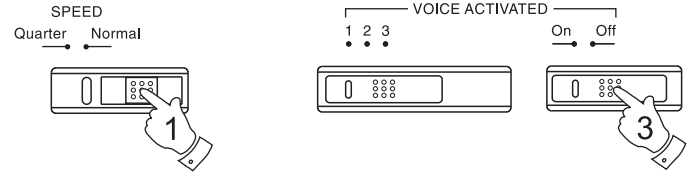



## Voice activated recording with timer

Your cassette recorder can also be programmed for a timed voice activated recording. This might be used to record sounds in a room at a certain time of day or to record a conference that you are unable to attend.

1. For highest quality recordings set the **Speed switch** to the "Normal" position. For maximum recording time set the **Speed switch** to the "Quarter" position
2. Set the timer as instructed on page 13-15.
3. Insert a cassette with the tape facing towards you and the side on which you wish to record uppermost. Close the cassette compartment. Reset the **Tape counter** if desired.
4. Set the **Voice Activated switch** to the 'On' position.
5. Press down the **Record button**.
6. The timer will activate the recorder but recordings will only be made when sound is present at the internal Microphone socket or Line in sockets.

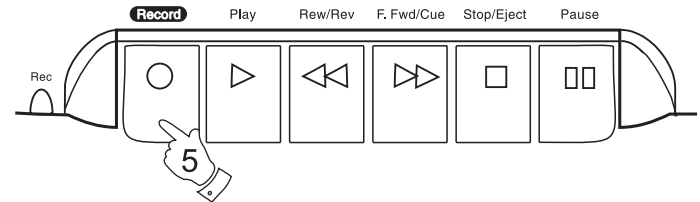
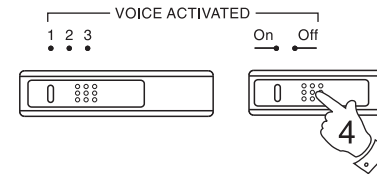
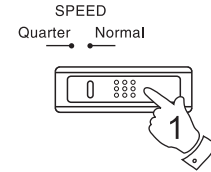

## Remote switch operation

Your cassette recorder can be switched on and off by another device connected to the **Timer Activation socket**. Some radios such as the Roberts R861 have a remote switch socket which enable the radio's timer to switch your cassette recorder on and off.

1. For highest quality recordings set the **Speed switch** to the "Normal" position. For maximum recording time set the **Speed switch** to the "Quarter" position.
2. Insert a cassette with the tape facing towards you and the side on which you wish to record uppermost. Close the cassette compartment. Reset the **Tape counter** if desired.
3. Plug one end of the supplied **Black patch cord** into the **Timer Activation socket**, plug the other end of the patch cord into your radio or other device's remote switch socket.
4. Plug the one end of the supplied **Red patch cord** into the line out or headphone socket on the device you are recording from and the other end into the **Line In socket** on your cassette recorder.
5. Set the **Voice Activated switch** to the 'Off' position.
6. Set the **Timer switch** to the "Off" position.
7. Press down the **Record button**.
8. Set your radio's timer to the required start time. Tune to the desired station. Your cassette recorder will commence recording when your radio's timer switches on and switches off when your radio's timer switches off.

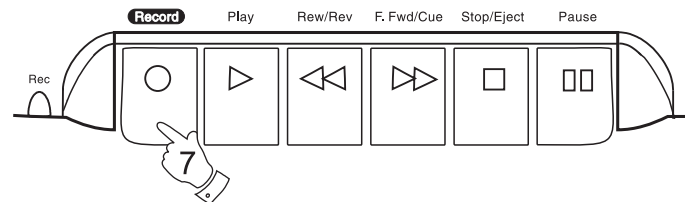
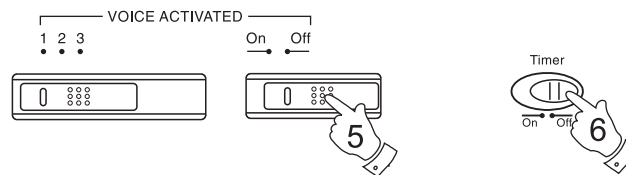
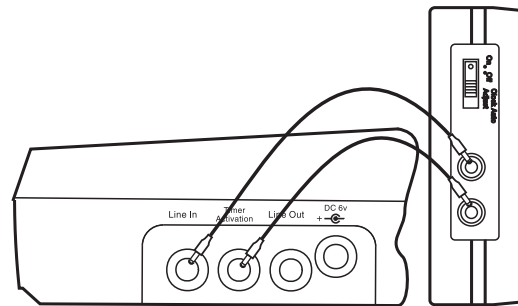
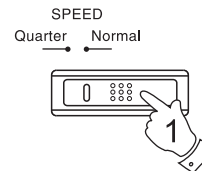

## Recording a telephone call

It is possible to purchase a BT socket recording lead from your local electronic component specialist (e.g. Maplin).

1. Connect the telephone recording lead to the **Mic socket** on the front of your cassette recorder.
2. Connect your telephone to the telephone record adaptor. (Refer to instructions included with the adaptor.)
3. Set the **Speed switch** to the required position.
4. Set the **Voice Activated switch** to the 'On' position.
5. Press the **Record button**.
6. Set **Voice Sensitivity switch** to position 2. Check recording starts when telephone conversation begins.
7. On the bottom of your cassette recorder there is a switch to insert a Beep into your recorded conversations at regular intervals to advise both parties that they are being recorded. Set the **Beep switch** to the 'On' position to activate this function.

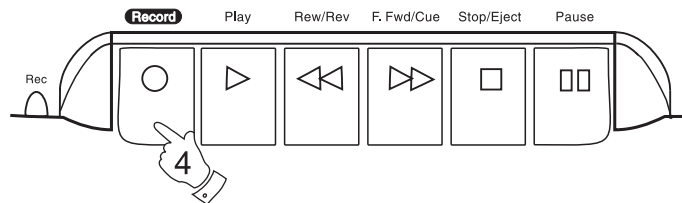
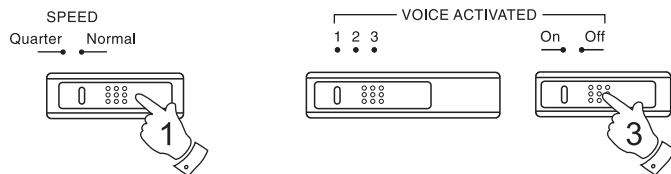
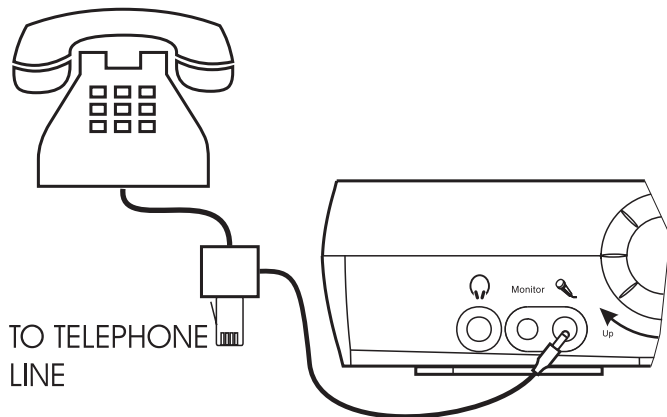

## Line out socket

Your cassette recorder can be used to playback through other equipment e.g. amplifiers, mini disc, or another cassette recorder.

1. Connect one end of the supplied **Green patch lead** to the **Line Out socket**. Connect the other end of the patch cord to the Line In socket of your amplifier or other equipment.
2. Press the **Stop/Eject button** to open the cassette compartment. Insert a cassette with the tape facing towards you and the side with the desired recording uppermost. Close the cassette compartment.
3. For normal pre-recorded tapes set the **Speed switch** to the Normal position.
4. Depress the **Play button**.
5. The output from the **Line Out socket** is not affected by the volume control.

**Note:** Your cassette recorder will playback tapes in stereo via the **Line Out socket**.

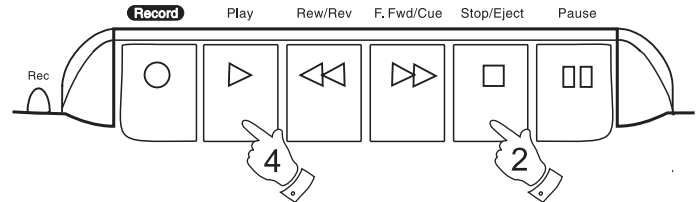
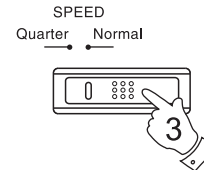
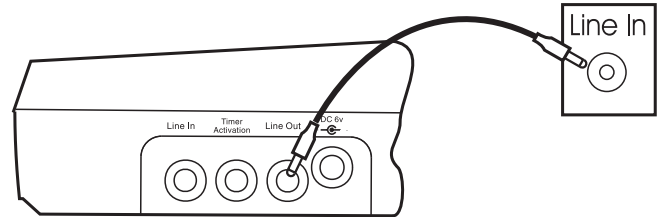

## Cassette tapes

High quality 90 min (C90) tapes are recommended for use in your cassette recorder. In tests these provide a balance between maximum recording time and prolonged tape life. Audio cassette tapes are available up to 120 minutes in length, however the tape material is thin and may stretch or break during recording or playback & are not recommended for use with your cassette recorder.

## Cleaning the heads

The binder and oxide from magnetic tapes can accumulate on the pinch roller (A) the capstan shaft (B) and also the heads (C and D). This will impair the sound quality.

To clean these parts proceed as follows:-

1. Turn off the power to the unit.
2. Press the Stop/Eject button.
3. Press the Play button and the heads will be clearly seen.
4. Clean the surfaces (A, B, C, D) with a lint free rag or cotton swab soaked in industrial alcohol. Press the stop/eject button as soon as cleaning is over.

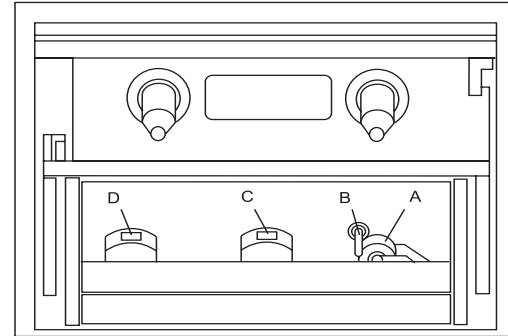

## Preventing accidental erasure

To safeguard your recordings against accidental erasure, break off the appropriate rear tab on the cassette as shown. There is one tab for each side of the cassette. This will prevent the **Record button** from being pressed. To restore the cassette to normal, seal the tab openings with a small piece of self-adhesive tape.

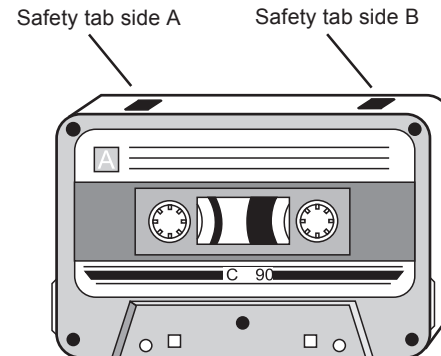

## General

Do not allow this unit to be exposed to water, steam or sand. Do not leave the unit where excessive heat could damage such as in a parked car where the heat from the sun can build up even though the outside temperature may not seem too high

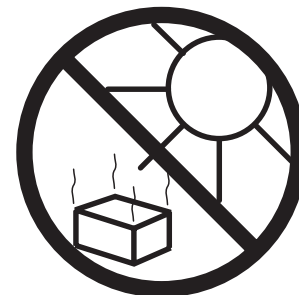
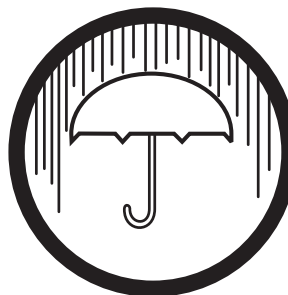

---

## Specifications

### Power Requirements

Mains	:	230V AC via adaptor supplied
DC	:	6.0V 
Batteries	:	4 x LR14 (C size) batteries

### Circuit Features

Semiconductors:	6 IC's , 28 Transistors , 27 diodes , 1 FET and 1 LED
Loudspeaker	75mm dia
Output Power	320mW
Headphone socket	3.5mm stereo
Microphone socket	3.5mm stereo input sensitivity 0.5mV
Line Input socket	3.5mm stereo input sensitivity 200mV
Timer activate socket	3.5mm

*The Company reserves the right to amend the specification without notice.*

## Guarantee

This unit is guaranteed for twelve months from the date of delivery to the original owner against failure due to faulty workmanship or component breakdown, subject to the procedure stated below. Should any component or part fail during this guarantee period it will be repaired or replaced free of charge.

The guarantee does not cover:

1. Damage resulting from incorrect use.
2. Consequential damage.
3. Product with removed or defaced serial numbers.

Procedure: Any claim under this guarantee should be made through the dealer from whom the instrument was purchased. It is likely that your Roberts' dealer will be able to attend to any defect quickly and efficiently but should it be necessary the dealer will return the instrument to the company's service department for attention. In the event that it is not possible to return the instrument to the Roberts' dealer from whom it was purchased, please contact Roberts Radio Technical Services at the address shown on the rear of this manual before taking further action.

*These statements do not affect the statutory rights of a consumer.*

**ROBERTS RADIO TECHNICAL SERVICES**

97-99 Worton Road  
Isleworth Middlesex  
TW7 6EG

Issue 1

Technical Helpline:-0208 758 0338

